

1. The diagram gives an outline of the process of aerobic respiration.

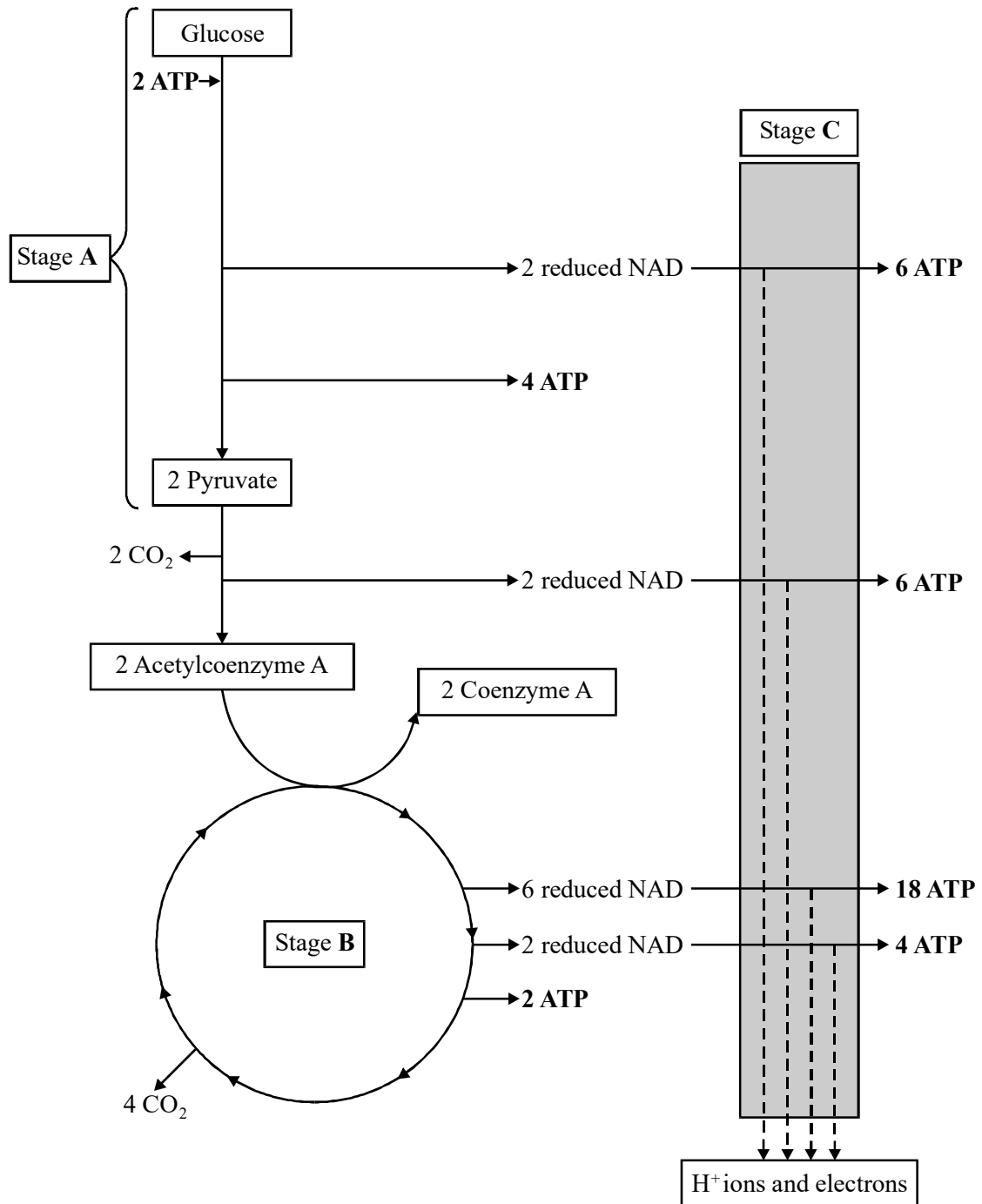

- (a) (i) Complete the table by naming stages **A** and **B** and giving the location of each stage in a cell such as a liver cell.

Stage	Name of stage	Location in cell
A		
B		

(2)

- (ii) How many carbon atoms are there in each pyruvate ion?

(1)

- (iii) What happens to the H⁺ ions and electrons released in stage **C**?

.....

.....

.....

(2)

- (b) In aerobic conditions, ATP is produced by substrate-level phosphorylation and by oxidative phosphorylation. Use information in the diagram to find the net yield of molecules of ATP per molecule of glucose by

- (i) substrate-level phosphorylation;

- (ii) oxidative phosphorylation.

(2)

- (c) (i) One mole of glucose releases 2880 kJ of energy when burned completely in oxygen. Hydrolysis of one mole of ATP to ADP and phosphate releases 31 kJ of energy. Use your answers from part (b) to calculate the percentage efficiency of energy transfer from glucose to ATP by aerobic respiration. Show your working.

Percentage efficiency =%

(2)

- (ii) What happens to the energy which is **not** transferred to ATP?

.....

(1)

- (iii) Explain why ATP is better than glucose as an immediate energy source for cell metabolism.

.....

(2)

- (iv) Give **three** uses of energy from ATP in a liver cell.

1
 2
 3

(3)

(Total 15 marks)

2. Read the following passage.

All mammals can dive. They are able to hold their breath and swim below the surface. For most of them, this is a very limited facility involving brief dives to depths of no more than a few metres. Seals, however, have many adaptations which allow them to spend far longer under water and to dive to much greater depths.

5 A diving human breathes in deeply and enters the water with the lungs fully inflated. Seals do not do this. They exhale before they dive. Full lungs would make it energetically expensive to swim down through the water. As they cannot take down an oxygen supply in the lungs, they must take it in other ways. Their main oxygen store is the blood.

10 Seals have greater blood volumes than terrestrial mammals. A Weddell seal, for example, has about 150 cm³ of blood per kg of body mass, twice the corresponding value for humans. In addition, the seal's blood contains more haemoglobin. The combined result is that the seal's oxygen store is over three times that of a human of comparable mass. Not only do seals have more haemoglobin in their blood, they also
15 have a higher concentration of another oxygen-binding pigment, myoglobin. Myoglobin is what makes meat red. The darker the meat, the greater the concentration of myoglobin. Weddell seal muscles are almost black, so great is the concentration of myoglobin. Crabeater seals forage for krill near the surface and their muscles are no darker than uncooked beef.

20 The combined store of oxygen in a 450 kg Weddell seal is about 30 litres. The average rate of oxygen consumption in tissue is about 250 cm³ kg⁻¹ hour⁻¹, so we can estimate how long the oxygen store should allow this seal to remain under water. We know, however, that Weddell seals can remain submerged for much longer than this. How do they do this?

25 When a seal dives, changes occur in its blood system. The brain is very sensitive to oxygen deprivation so its oxygen supply must be maintained. On the other hand, most other systems, such as the gut and muscles, are able to function without oxygen. When a seal dives, the heart rate slows right down. At the same time, a ring
30 of muscle, the caval sphincter, contracts round the main vein bringing blood back to the heart from the abdomen. This prevents any more blood returning from the liver, gut and muscles of the back. Blood flow to the brain is unimpeded although that to the rest of the body is reduced by about 90%.

35 Once their oxygen stores are exhausted, the organs outside the heart-brain-lung
 system continue to derive energy anaerobically from glycolysis and to accumulate
 lactate. It is the accumulation of lactate in the muscles which gives rise to fatigue.
 During rest and recovery, this lactate is processed in the liver. Blood samples from
 Weddell seals have shown that there is no significant increase in blood lactate
 concentrations until the dive time exceeds 25 minutes. After this, lactate accumulates
 and reaches a concentration of about 230 mg per 100 cm³ in dives of 60 minutes
 40 duration.

Source: adapted from BONNER, *Seals and sea lions of the world* (Blandford) 1994

Use information from the passage and your own knowledge to answer the following questions.

- (a) Explain why full lungs would make it 'energetically expensive to swim down through the water' (lines 6-7).

.....

.....

.....

.....

(2)

- (b) (i) The graph shows the dissociation curve for myoglobin.

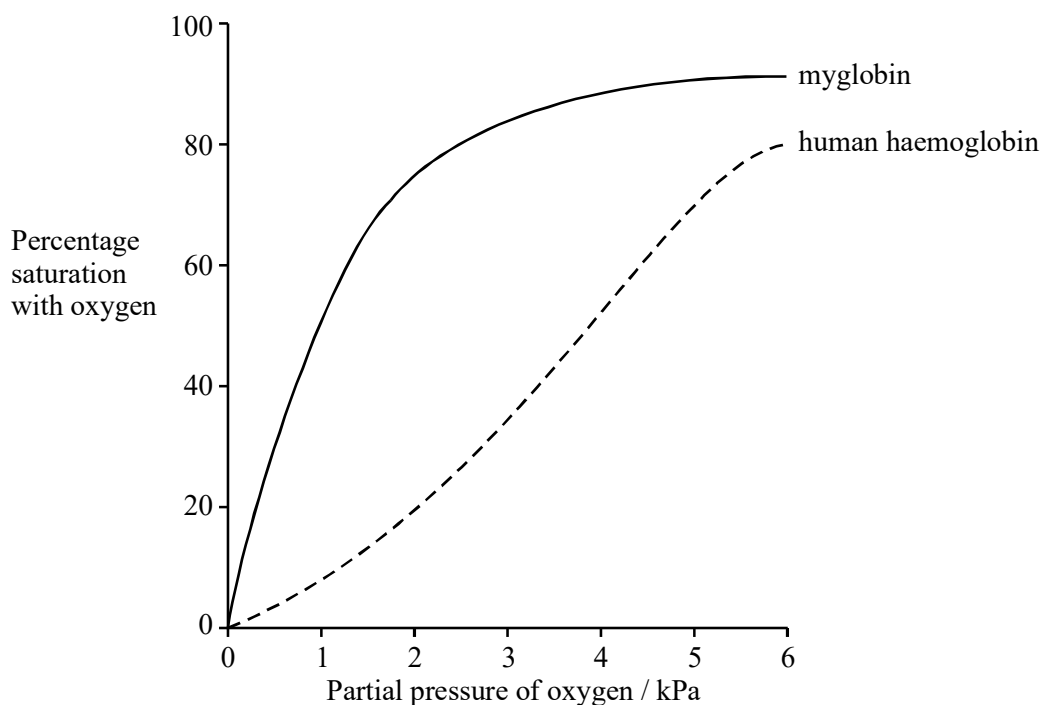

Use this graph to explain how the presence of myoglobin in its muscles can be of benefit to a seal.

.....
.....
.....
.....

(2)

(ii) Weddell seals get their food by diving to great depths. Explain the link between the colour of a Weddell seal's muscles and the animal's diving habits.

.....
.....
.....
.....
.....
.....

(3)

(c) (i) Use the figures in paragraph 4 to calculate the time you would expect a 450 kg Weddell seal to be able to remain under water, respiring aerobically. Explain your working.

Answer

(2)

(ii) Weddell seals can remain under water for longer than this. Describe **two** adaptations of the blood system which allow them to remain under water longer.

1

.....

2

.....

(2)

(d) Describe **one** way in which the change in blood flow to the organs of the body of a diving seal differs from that in a human undergoing moderate exercise.

.....

.....

(1)

(Total 12 marks)

3. The diagram summarises the five main stages in respiration in an animal cell. The boxes show the number of carbon atoms in various molecules or ions.

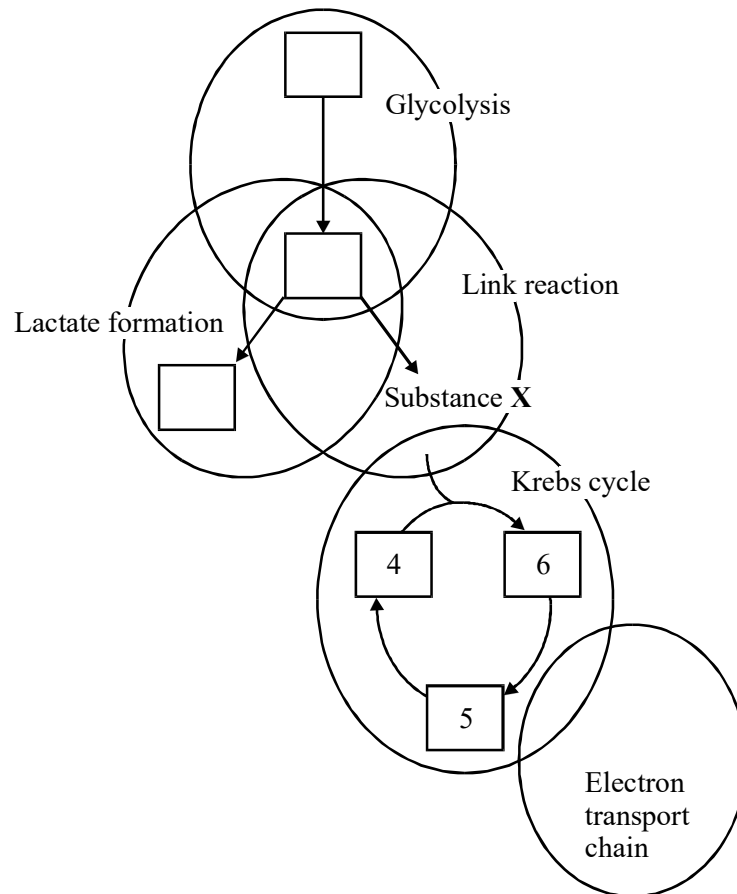

- (a) Complete the diagram by filling in the three empty boxes with the relevant number of carbon atoms.

(1)

- (b) Name

- (i) substance X;

.....

(1)

(ii) **two** stages shown in the diagram in which carbon dioxide is produced.

1

2

(1)

(c) During glycolysis, NAD is reduced. Explain what happens to this reduced NAD when the cell is respiring anaerobically.

.....

(2)

(Total 5 marks)

4. The diagram summarises the process of anaerobic respiration in yeast cells.

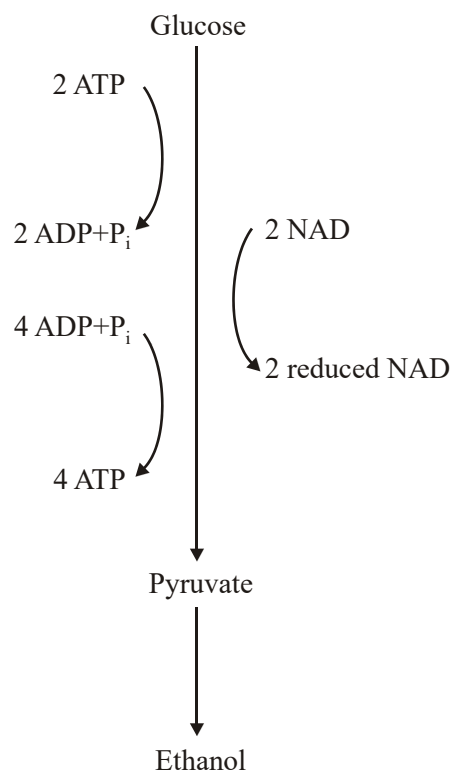

(a) (i) In anaerobic respiration, what is the net yield of ATP molecules per molecule of glucose?

.....

(1)

(ii) Give **two** advantages of ATP as an energy-storage molecule within a cell.

1

.....

2

.....

(2)

(b) Describe how NAD is regenerated in anaerobic respiration in yeast cells.

.....

.....

(1)

(c) The respiratory quotient (RQ) for yeast respiring aerobically and using glucose as a substrate is 1.0. However, some students found the RQ of yeast respiring glucose to be 1.6. Assuming that their technique was correct, explain how this is possible.

.....

.....

.....

.....

(2)

(Total 6 marks)

5. The diagram shows the main steps in the biochemical pathways involved in respiration.

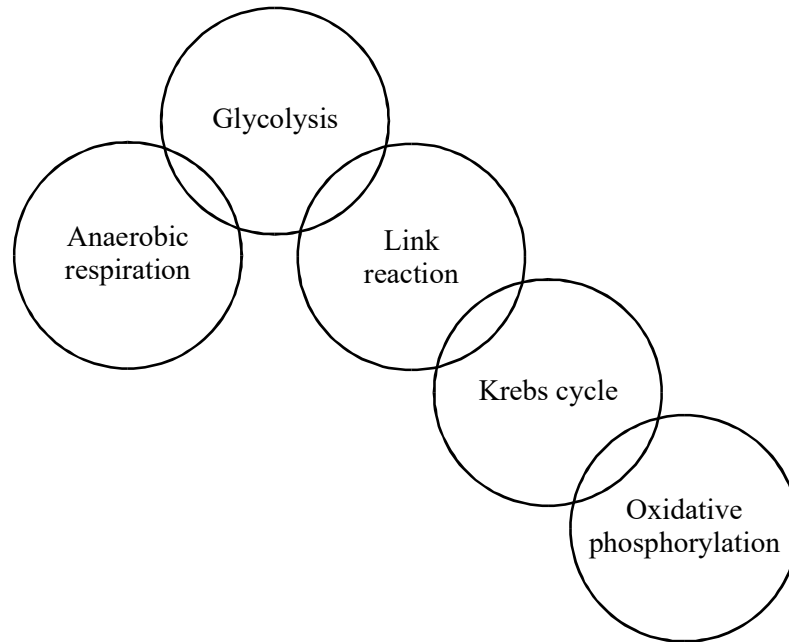

- (a) (i) Which step or steps take place on the cristae of the mitochondria?

.....

(1)

- (ii) In which step or steps is carbon dioxide produced in an animal cell?

.....

(1)

- (b) If a pond freezes over during the winter, goldfish can remain alive in the water under the ice. Explain why they use the carbohydrate stores in their bodies much faster in these conditions.

.....

.....

.....

(2)

- (c) What is the main difference between the way in which ATP is produced by oxidative phosphorylation and the way in which it is produced in photosynthesis?

.....

(1)
 (Total 5 marks)

6. Complete the table with a tick if the statement is true about the particular stage of respiration.

Stage of respiration	Statement		
	ATP produced	Carbon dioxide produced	Reduced NAD converted to NAD
Glucose → pyruvate			
Pyruvate → acetylcoenzyme A			
Krebs cycle			
Electron carrier chain			

(Total 4 marks)

7. In an investigation, ultracentrifugation was used to separate the components of liver cells. The flow chart summarises the steps in the process.

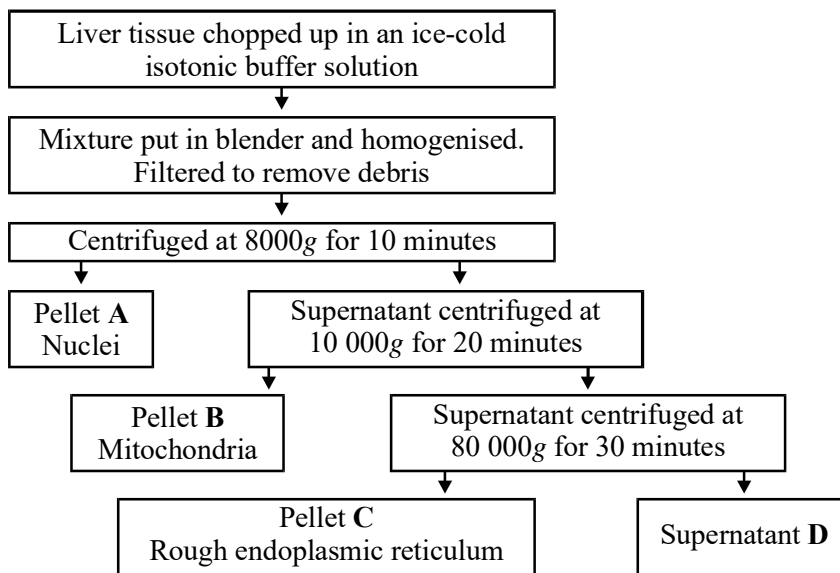

(a) Explain why it was necessary to chop up the liver in a buffer solution.

.....

.....

.....

.....

(2)

(b) Explaining your answer in each case, which of pellets **A**, **B** or **C** would be associated with:

(i) the highest concentration of DNA;

.....

.....

.....

(ii) polymerisation of amino acids?

.....
.....
.....

(4)

(c) Describe a biochemical test that would enable you to demonstrate that supernatant **D** contained protein.

.....
.....
.....

(2)

(Total 8 marks)

8. The diagram shows anaerobic respiration in yeast.

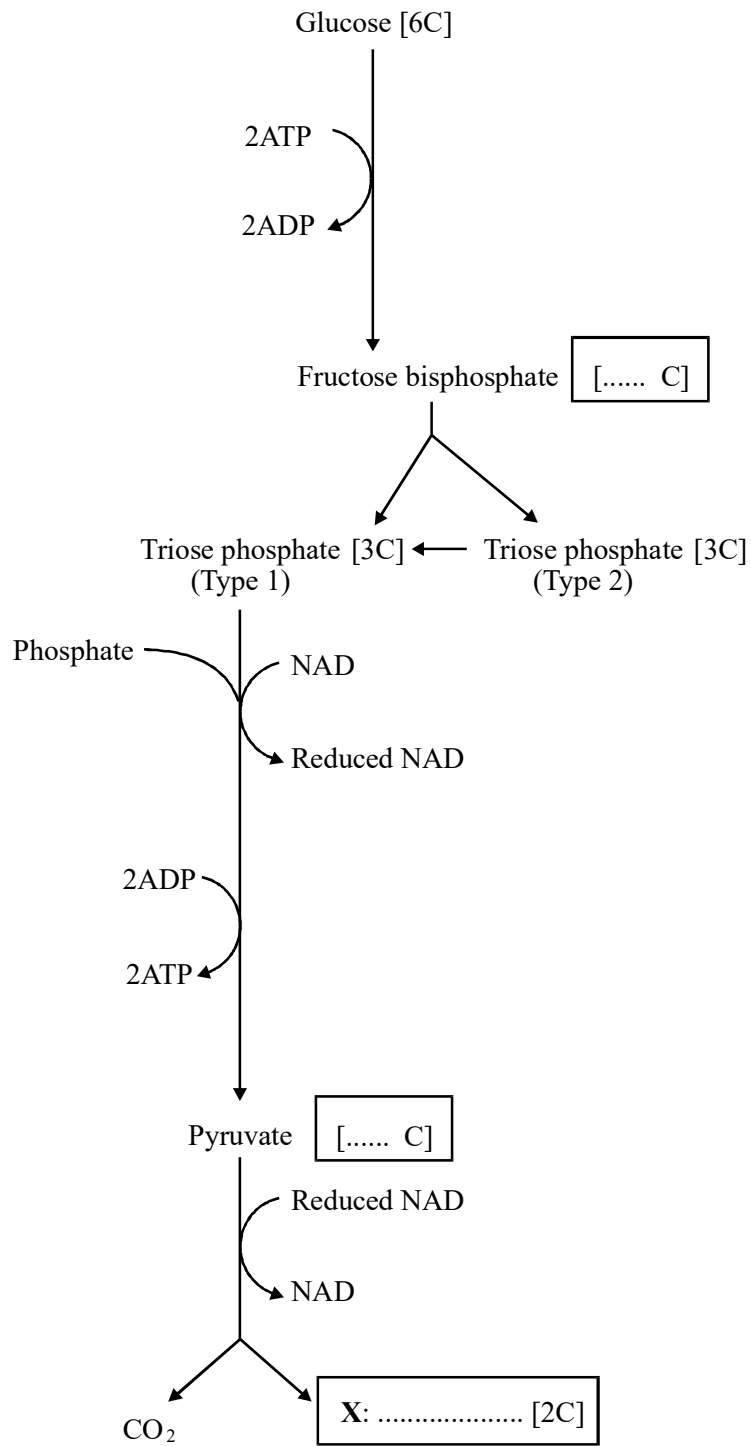

(a) Complete the boxes in the diagram to show:

(i) the number of carbon atoms in each molecule of fructose bisphosphate and in each molecule of pyruvate;

(1)

(ii) the name of compound X.

(1)

(b) Under anaerobic conditions, the oxidised form of NAD is regenerated. Explain why this is essential.

.....
.....

(1)

(c) In the reactions shown in the diagram, what is the net gain of ATP molecules per molecule of glucose? Explain how you worked out your answer.

.....
.....

(2)

(Total 5 marks)

9. The diagram shows the flow of energy through a marine ecosystem. The units are $\text{kJ m}^{-2} \text{ year}^{-1}$.

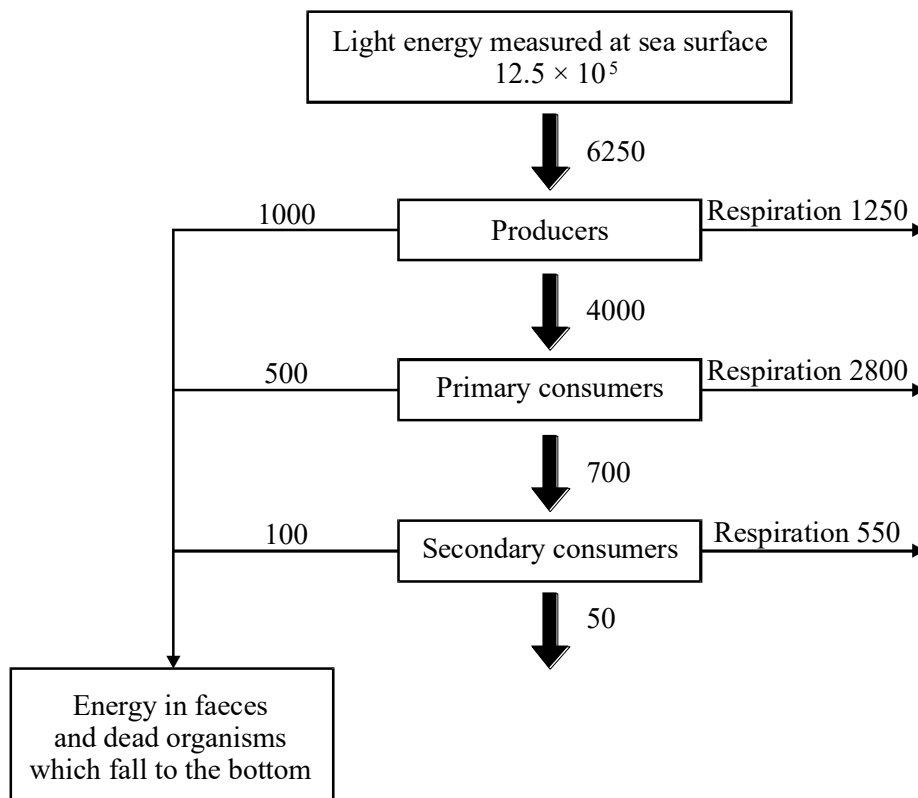

- (a) (i) Calculate the percentage of the light energy at the sea surface which is converted into chemical energy in the producers. Show your working. (2)
- (ii) The percentage of the light energy at the sea surface which is converted into chemical energy in the producers is very small. Give **two** reasons for this. (2)
- (b) Use the information in the diagram to explain why marine ecosystems such as this rarely have more than five trophic levels. (2)
- (c) What happens to the energy in faeces and dead organisms which fall to the bottom of the sea? (2)

- (d) Light energy is important in the light-dependent reaction of photosynthesis. The energy changes which take place in the light-dependent reaction are shown in the diagram.

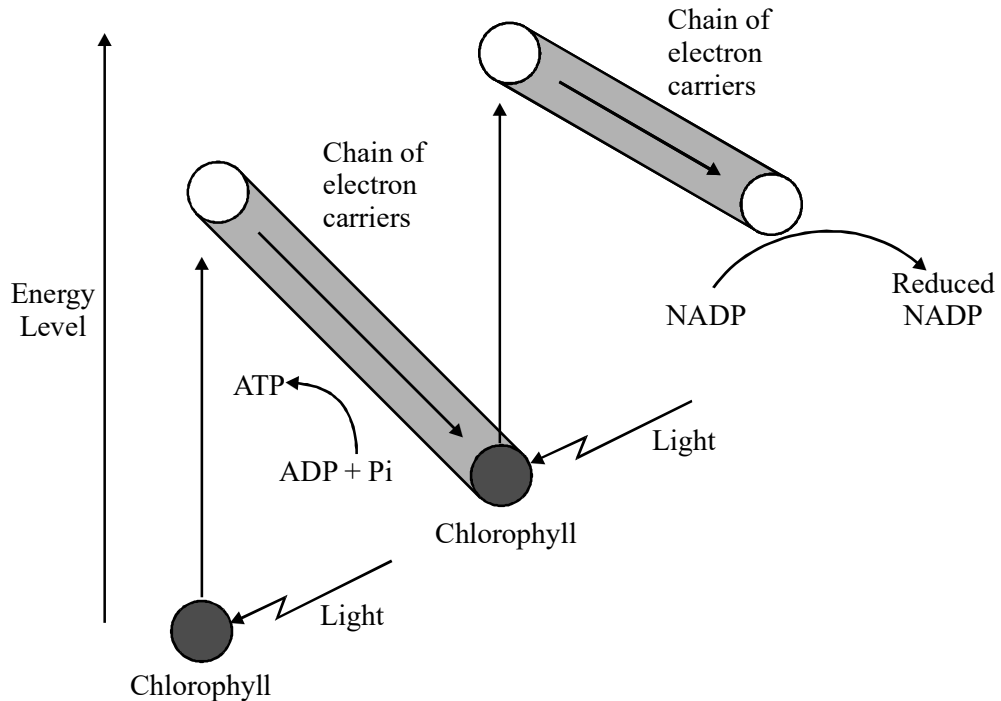

- (i) Describe what happens to the chlorophyll when it is struck by light. (2)
- (ii) The weedkiller DCMU blocks the flow of electrons along the chains of electron carriers. Describe and explain the effect this will have on the production of triose phosphate in the light-independent reaction. (3)
- (e) Living organisms release energy from organic molecules such as glucose during respiration. Much of this energy is used to produce ATP. Explain why ATP is better than glucose as an immediate energy source for cell metabolism. (2)

(f) The production of ATP is said to be coupled to the transport of electrons along the carrier chain. Normally, electrons are only passed along the carrier chain if ADP is being converted to ATP at the same time. When the amount of ADP in a cell is low, electrons do not flow from reduced coenzyme to oxygen.

(i) Suggest how the rate of respiration is linked to the needs of the cell.

(3)

(ii) DNP is a substance which allows electron transport to take place without the production of ATP. When DNP is given to rats, their body temperatures rise. Explain why.

(2)

(Total 20 marks)

10. The diagram gives an outline of the process of aerobic respiration.

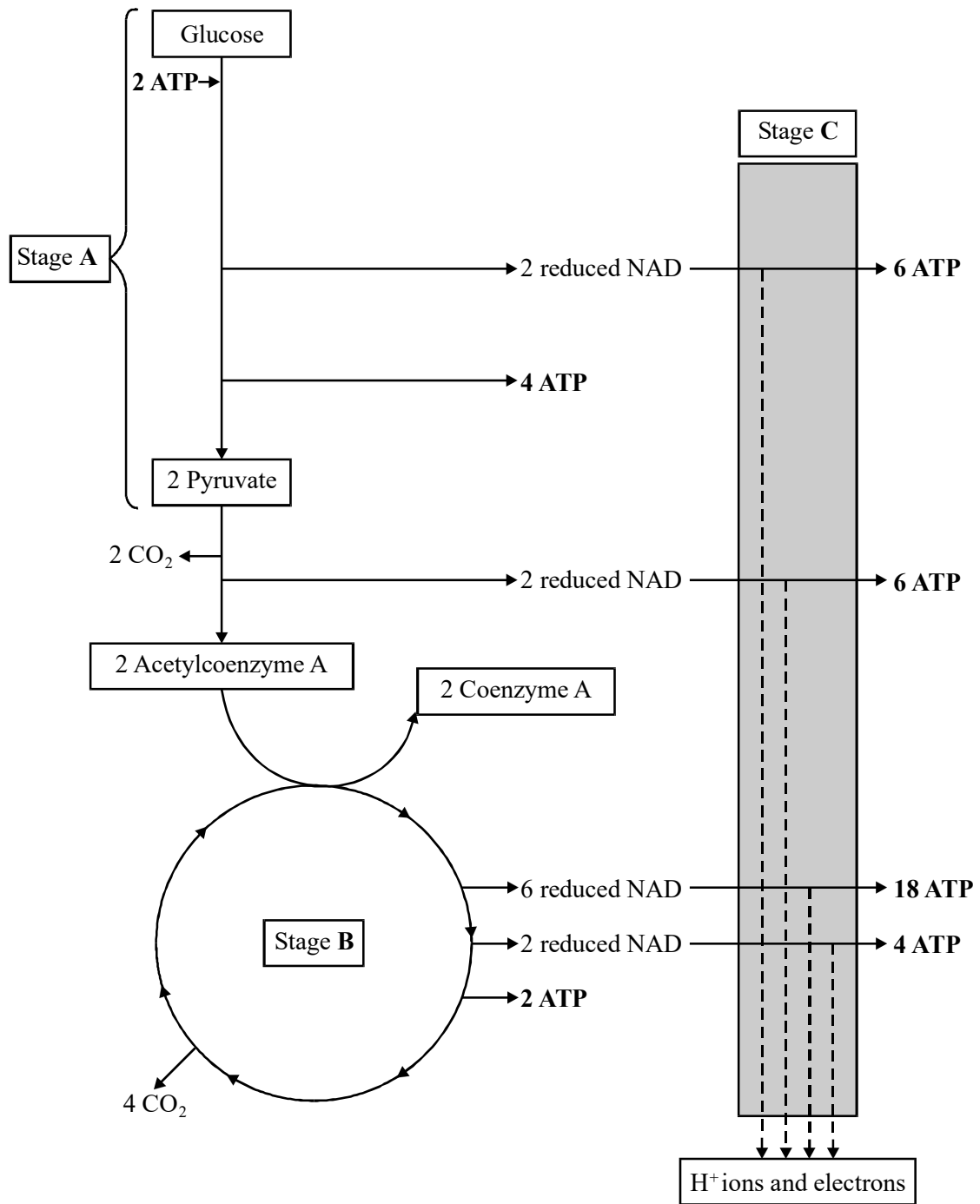

- (a) (i) Complete the table by naming stages **A** and **B** and giving the location of each stage in a cell such as a liver cell.

Stage	Name of stage	Location in cell
A		
B		

(2)

- (ii) How many carbon atoms are there in each pyruvate ion?

(1)

- (iii) What happens to the H^+ ions and electrons released in stage **C**?

.....

.....

.....

(2)

- (b) In aerobic conditions, ATP is produced by substrate-level phosphorylation and by oxidative phosphorylation. Use information in the diagram to find the net yield of molecules of ATP per molecule of glucose by

(i) substrate-level phosphorylation;

(ii) oxidative phosphorylation.

(2)

- (c) (i) One mole of glucose releases 2880 kJ of energy when burned completely in oxygen. Hydrolysis of one mole of ATP to ADP and phosphate releases 31 kJ of energy. Use your answers from part (b) to calculate the percentage efficiency of energy transfer from glucose to ATP by aerobic respiration. Show your working.

Percentage efficiency =%

(2)

- (ii) What happens to the energy which is **not** transferred to ATP?

.....

(1)

- (iii) Explain why ATP is better than glucose as an immediate energy source for cell metabolism.

.....

(2)

- (iv) Give **three** uses of energy from ATP in a liver cell.

- 1
- 2
- 3

(3)

(Total 15 marks)

11. Read the following passage.

All mammals can dive. They are able to hold their breath and swim below the surface. For most of them, this is a very limited facility involving brief dives to depths of no more than a few metres. Seals, however, have many adaptations which allow them to spend far longer under water and to dive to much greater depths.

5 A diving human breathes in deeply and enters the water with the lungs fully inflated. Seals do not do this. They exhale before they dive. Full lungs would make it energetically expensive to swim down through the water. As they cannot take down an oxygen supply in the lungs, they must take it in other ways. Their main oxygen store is the blood.

10 Seals have greater blood volumes than terrestrial mammals. A Weddell seal, for example, has about 150 cm³ of blood per kg of body mass, twice the corresponding value for humans. In addition, the seal's blood contains more haemoglobin. The combined result is that the seal's oxygen store is over three times that of a human of comparable mass. Not only do seals have more haemoglobin in their blood, they also
15 have a higher concentration of another oxygen-binding pigment, myoglobin. Myoglobin is what makes meat red. The darker the meat, the greater the concentration of myoglobin. Weddell seal muscles are almost black, so great is the concentration of myoglobin. Crabeater seals forage for krill near the surface and their muscles are no darker than uncooked beef.

20 The combined store of oxygen in a 450 kg Weddell seal is about 30 litres. The average rate of oxygen consumption in tissue is about 250 cm³ kg⁻¹ hour⁻¹, so we can estimate how long the oxygen store should allow this seal to remain under water. We know, however, that Weddell seals can remain submerged for much longer than this. How do they do this?

25 When a seal dives, changes occur in its blood system. The brain is very sensitive to oxygen deprivation so its oxygen supply must be maintained. On the other hand, most other systems, such as the gut and muscles, are able to function without oxygen. When a seal dives, the heart rate slows right down. At the same time, a ring of muscle, the caval sphincter, contracts round the main vein bringing blood back to
30 the heart from the abdomen. This prevents any more blood returning from the liver, gut and muscles of the back. Blood flow to the brain is unimpeded although that to the rest of the body is reduced by about 90%.

Once their oxygen stores are exhausted, the organs outside the heart-brain-lung system continue to derive energy anaerobically from glycolysis and to accumulate lactate. It is the accumulation of lactate in the muscles which gives rise to fatigue. During rest and recovery, this lactate is processed in the liver. Blood samples from Weddell seals have shown that there is no significant increase in blood lactate concentrations until the dive time exceeds 25 minutes. After this, lactate accumulates and reaches a concentration of about 230 mg per 100 cm³ in dives of 60 minutes duration.

Source: adapted from BONNER, *Seals and sea lions of the world* (Blandford) 1994

Use information from the passage and your own knowledge to answer the following questions.

- (a) Explain why full lungs would make it 'energetically expensive to swim down through the water' (lines 6-7).

.....

.....

.....

.....

(2)

- (b) (i) The graph shows the dissociation curve for myoglobin.

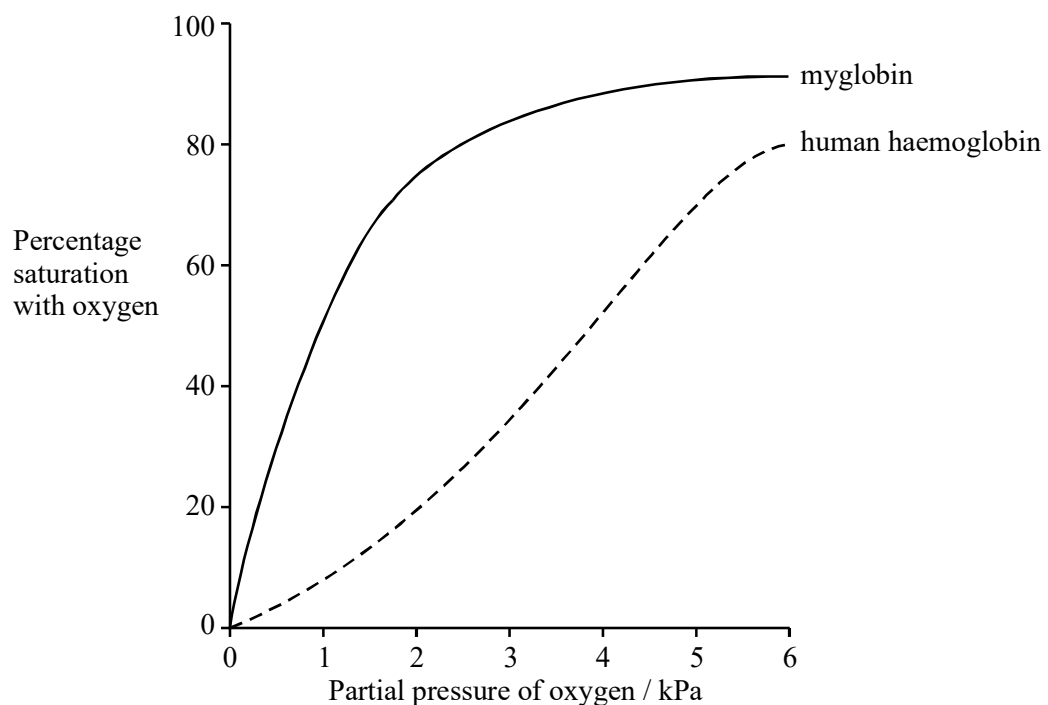

Use this graph to explain how the presence of myoglobin in its muscles can be of benefit to a seal.

.....
.....
.....
.....

(2)

(ii) Weddell seals get their food by diving to great depths. Explain the link between the colour of a Weddell seal's muscles and the animal's diving habits.

.....
.....
.....
.....
.....
.....

(3)

(c) (i) Use the figures in paragraph 4 to calculate the time you would expect a 450 kg Weddell seal to be able to remain under water, respiring aerobically. Explain your working.

Answer

(2)

(ii) Weddell seals can remain under water for longer than this. Describe **two** adaptations of the blood system which allow them to remain under water longer.

- 1
-
- 2
-

(2)

(d) Describe **one** way in which the change in blood flow to the organs of the body of a diving seal differs from that in a human undergoing moderate exercise.

-
-

(1)

(Total 12 marks)

12. ATP links energy-releasing (exergonic) reactions with energy-requiring (endergonic) reactions. The diagram shows some of these reactions.

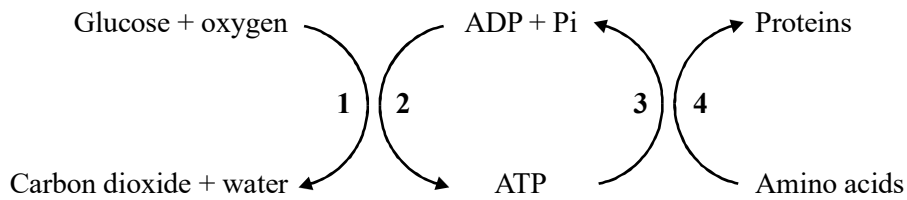

(a) Give the numbers in the diagram that correspond to *exergonic* reactions.

-

(1)

(b) Explain why the total energy released from an exergonic reaction is not all available for the linked endergonic reaction.

-
-

(1)

- (c) The diagram shows some of the reactions of respiration.

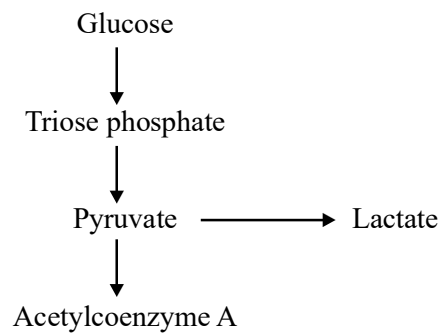

On the diagram, draw and label **one** arrow to show a reaction that

- (i) requires ATP (label this arrow **ATP in**);
- (ii) produces ATP (label this arrow **ATP out**).

(2)

- (d) The table shows the maximum number of ATP molecules that can be produced from a single molecule of glucose during the stages of respiration.

Stage	Maximum number of molecules of ATP produced during stage
Glycolysis	4
Krebs cycle	2
Oxidative phosphorylation	34

How many of these molecules of ATP are produced in the cytoplasm?

.....

(1)

(e) In a photosynthesising leaf, reduced NADP is produced during the light-dependent reactions.

(i) Where in chloroplasts do the light-dependent reactions take place?

.....

(1)

(ii) Describe how reduced NADP is involved in the light-independent reactions of photosynthesis.

.....

(2)

DCPIP is a blue dye that can be converted to colourless reduced DCPIP by gaining electrons. This is summarised below.

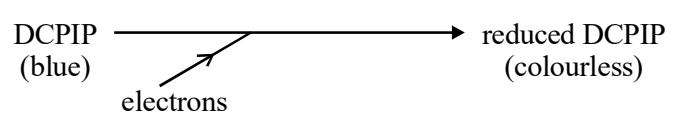

A chloroplast suspension was made by grinding fresh leaves in buffer solution and centrifuging the mixture. Tubes were prepared and treated in different ways. The colour of the tube contents was recorded at the start and after 15 minutes. This information is summarised in the table.

Tube	Contents	Treatment	Colour	
			at start	after 15 minutes
A	2 cm ³ chloroplast suspension 6 cm ³ DCPIP	tube kept in bright light	blue / green	green
B	2 cm ³ chloroplast suspension 6 cm ³ DCPIP	tube kept in dark	blue / green	blue / green
C	2 cm ³ buffer solution 6 cm ³ DCPIP	tube kept in bright light	blue	blue

(f) (i) Tube **C** was included as a control. Explain why this control was necessary in the investigation.

.....
.....

(1)

(ii) Explain the colour of tube **A** after 15 minutes.

.....
.....
.....
.....
.....
.....

(3)

(g) (i) The chloroplast suspension produced by centrifugation may also contain mitochondria. Explain the evidence from tube **B** that mitochondria are not responsible for reducing the DCPIR.

.....
.....
.....
.....

(2)

(ii) Suggest why conclusions made only on the basis of the data in the table may not be reliable.

.....
.....

(1)

(Total 15 marks)

13. (a) ATP is sometimes described as an *immediate* source of energy. Explain why.

.....
.....

(1)

- (b) Plants produce ATP in the light-dependent reaction of photosynthesis. Explain why plants cannot use this as their only source of ATP.

.....
.....
.....
.....

(2)

- (c) Red blood cells do not contain mitochondria but they use ATP. By what process do red blood cells produce ATP? Suggest a reason for your answer.

Process

Reason

.....
.....

(2)

(Total 5 marks)

14. The diagram summarises the five main stages in respiration in an animal cell. The boxes show the number of carbon atoms in various molecules or ions.

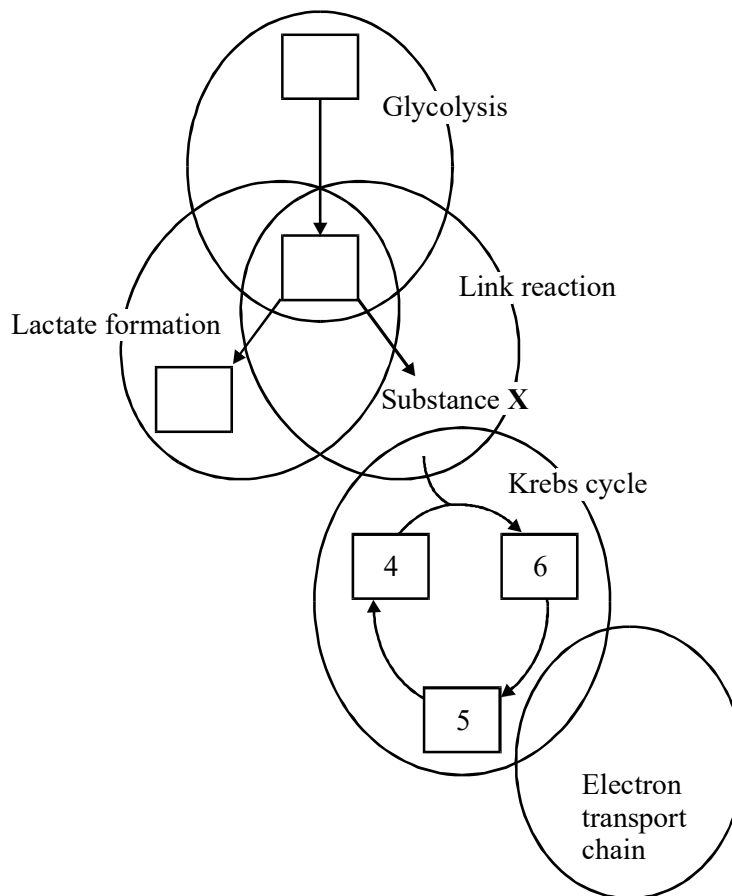

- (a) Complete the diagram by filling in the three empty boxes with the relevant number of carbon atoms.

(1)

- (b) Name

- (i) substance X;

.....

(1)

(ii) **two** stages shown in the diagram in which carbon dioxide is produced.

1

2

(1)

(c) During glycolysis, NAD is reduced. Explain what happens to this reduced NAD when the cell is respiring anaerobically.

.....
.....
.....
.....

(2)

(Total 5 marks)

15. The diagram gives an outline of the process of aerobic respiration.

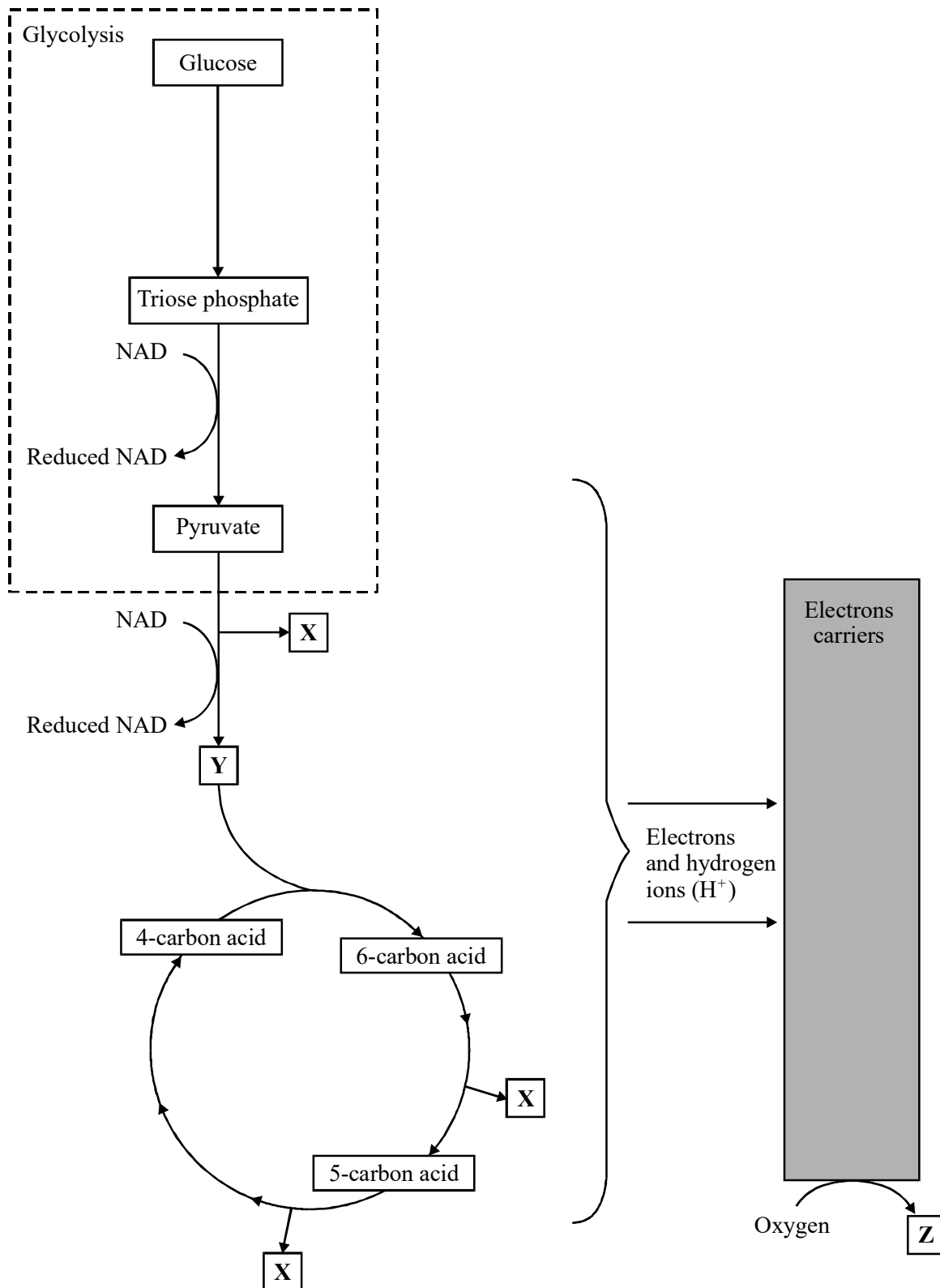

(a) Name substances **X**, **Y** and **Z**.

X

Y

Z

(3)

(b) Give the location of each of the following in a liver cell.

(i) Glycolysis

(ii) The Krebs cycle

(2)

(c) (i) Write the letter **A** on the diagram to show **one** step where ATP is used.

(ii) Write the letter **B** on the diagram at **two** steps where ATP is produced.

(3)

(d) Apart from respiration, give **three** uses of ATP in a liver cell.

1

2

3

(3)

- (e) Human skeletal muscle can respire both aerobically and anaerobically. Describe what happens to pyruvate in anaerobic conditions and explain why anaerobic respiration is advantageous to human skeletal muscle.

.....

.....

.....

.....

.....

.....

.....

.....

.....

(4)
(Total 15 marks)

16. The diagram summarises the process of anaerobic respiration in yeast cells.

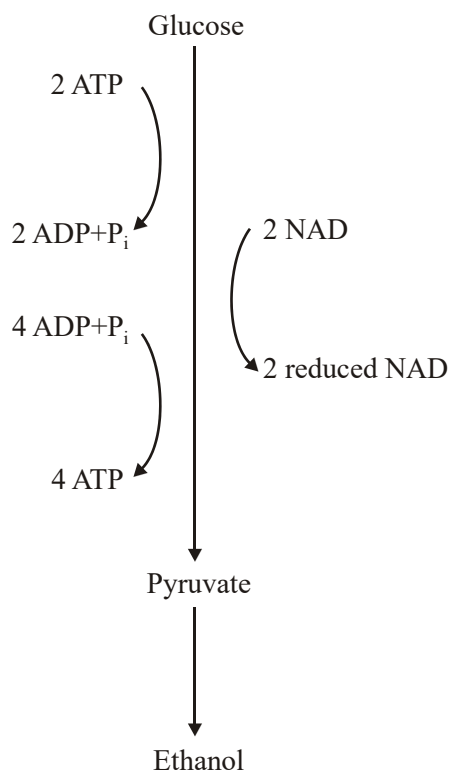

(a) (i) In anaerobic respiration, what is the net yield of ATP molecules per molecule of glucose?

.....

(1)

(ii) Give **two** advantages of ATP as an energy-storage molecule within a cell.

1

.....

2

.....

(2)

(b) Describe how NAD is regenerated in anaerobic respiration in yeast cells.

.....

.....

(1)

(c) The respiratory quotient (RQ) for yeast respiring aerobically and using glucose as a substrate is 1.0. However, some students found the RQ of yeast respiring glucose to be 1.6. Assuming that their technique was correct, explain how this is possible.

.....

.....

.....

.....

(2)

(Total 6 marks)

17. The diagram shows some of the stages in two processes that produce ATP.

Process 1

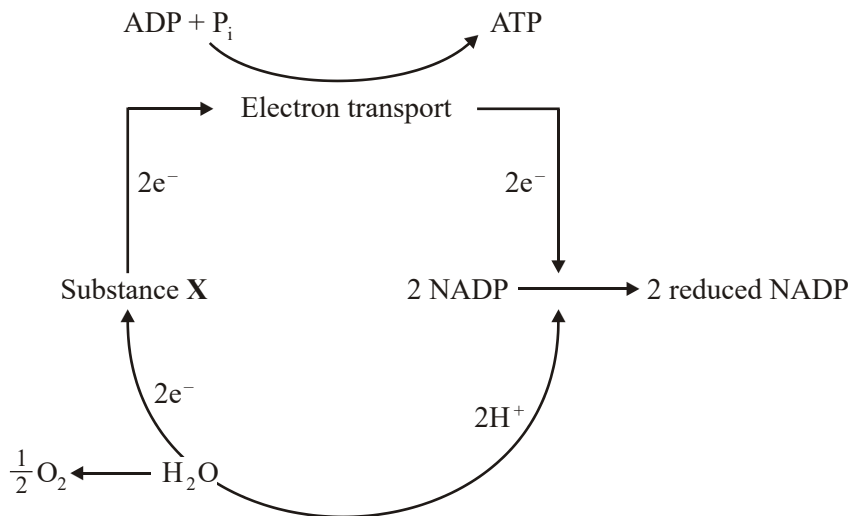

Process 2

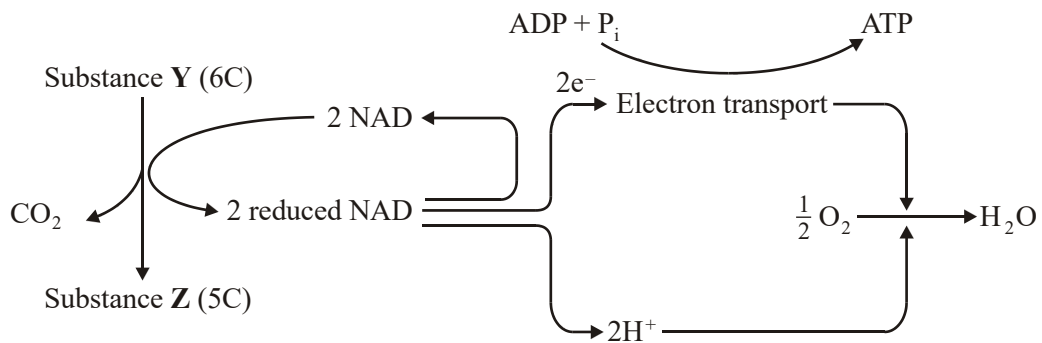

(a) In **Process 1**, what causes substance **X** to lose electrons (e^-)?

.....

(1)

(b) Where precisely, within a cell, does electron transport take place in **Process 2**?

.....

(1)

- (c) Name **one** kingdom which contains organisms that can produce ATP using both processes. Explain your choice.

.....

.....

.....

.....

(2)
(Total 4 marks)

18. (a) The main stages in anaerobic respiration in yeast are shown in the diagram.

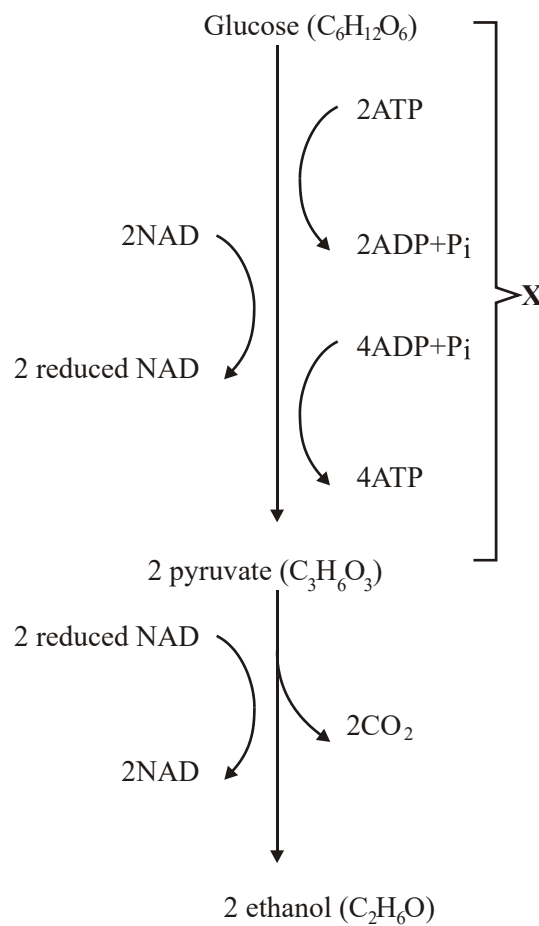

- (i) Name process X.

.....

(1)

(ii) Give **one** piece of evidence from the diagram which suggests that the conversion of pyruvate to ethanol involves reduction.

.....
.....

(1)

(iii) Explain why converting pyruvate to ethanol is important in allowing the continued production of ATP in anaerobic respiration.

.....
.....
.....
.....

(2)

(b) Give **two** ways in which anaerobic respiration of glucose in yeast is

(i) similar to anaerobic respiration of glucose in a muscle cell;

1
.....
2
.....

(2)

(ii) different from anaerobic respiration of glucose in a muscle cell.

1
.....
2
.....

(2)

- (c) Some students investigated the effect of temperature on the rate of anaerobic respiration in yeast. The apparatus they used is shown in the diagram. The yeast suspension was mixed with glucose solution and the volume of gas collected in five minutes was recorded.

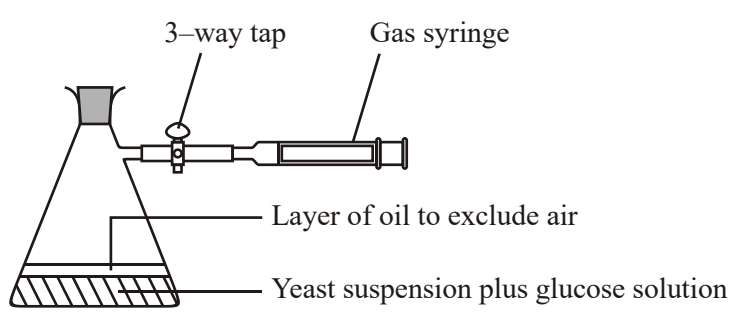

- (i) Each student repeated the experiment and the results were pooled. Explain the advantages of collecting a large number of results.

.....

.....

.....

.....

(2)

- (ii) At 30°C, one student obtained the following results.

Volume of gas collected in 5 minutes / cm ³	Result 1	Result 2	Result 3
	38.3	27.6	29.4

Calculate the mean rate of gas production. Give your answer in cm³ s⁻¹.

Answer cm³ s⁻¹

(2)

- (iii) If aerobic respiration had been investigated rather than anaerobic respiration, how would you expect the volumes of gas collected at 30°C to differ from these results? Explain your answer.

.....

.....

.....

.....

.....

.....

(3)
(Total 15 marks)

- 19.** *Write an essay on the following topic. You should select and use information from different parts of the specification. Credit will be given for the biological content. It will also be given for the selection and use of relevant information, and for the organisation and presentation of the essay.*

Inorganic ions include those of sodium, phosphorus and hydrogen.
Describe how these and other inorganic ions are used in living organisms.

(Total 25 marks)

20. (a) The flow chart shows the main stages in aerobic respiration.

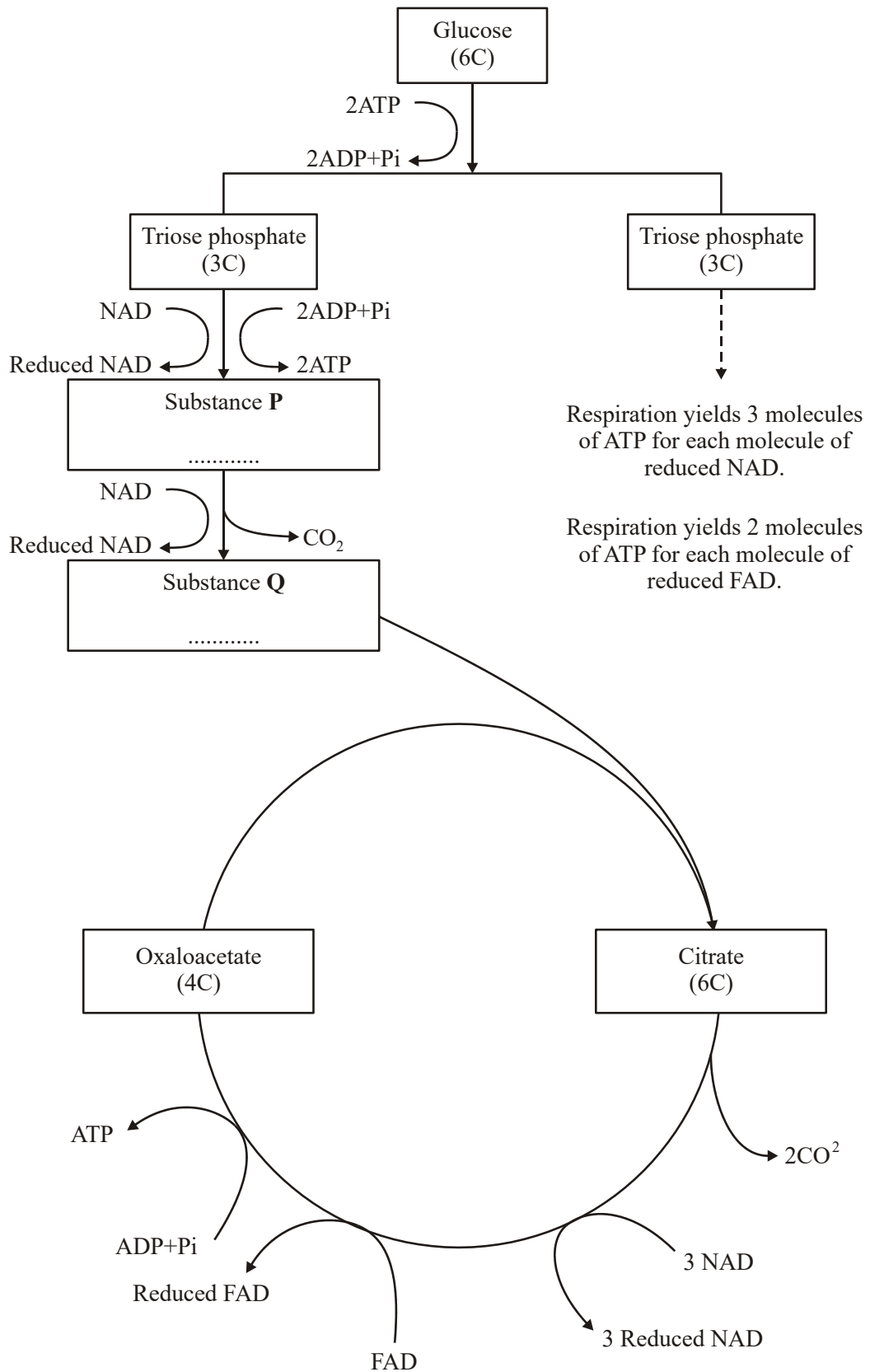

(i) Complete the flow chart by writing, in the appropriate boxes, the number of carbon atoms in substance **P** and the name of substance **Q**.

(2)

(ii) Some ATP is formed in the cytoplasm and some in the mitochondria. Use the information given to calculate the number of molecules of ATP formed in a mitochondrion from one molecule of glucose in aerobic respiration. Show how you arrived at your answer.

Answer.....

(2)

(iii) In the presence of oxygen, respiration yields more ATP per molecule of glucose than it does in the absence of oxygen. Explain why.

.....
.....
.....
.....
.....
.....

(3)

- (b) *Anabaena* is a prokaryote found inside the leaves of a small fern. *Anabaena* can produce ammonia from nitrogen (nitrogen fixation). This reaction only takes place in the anaerobic conditions found in cells called heterocysts. Heterocysts are thick-walled cells that do not contain chlorophyll. The drawing shows the relationship between *Anabaena* and the fern.

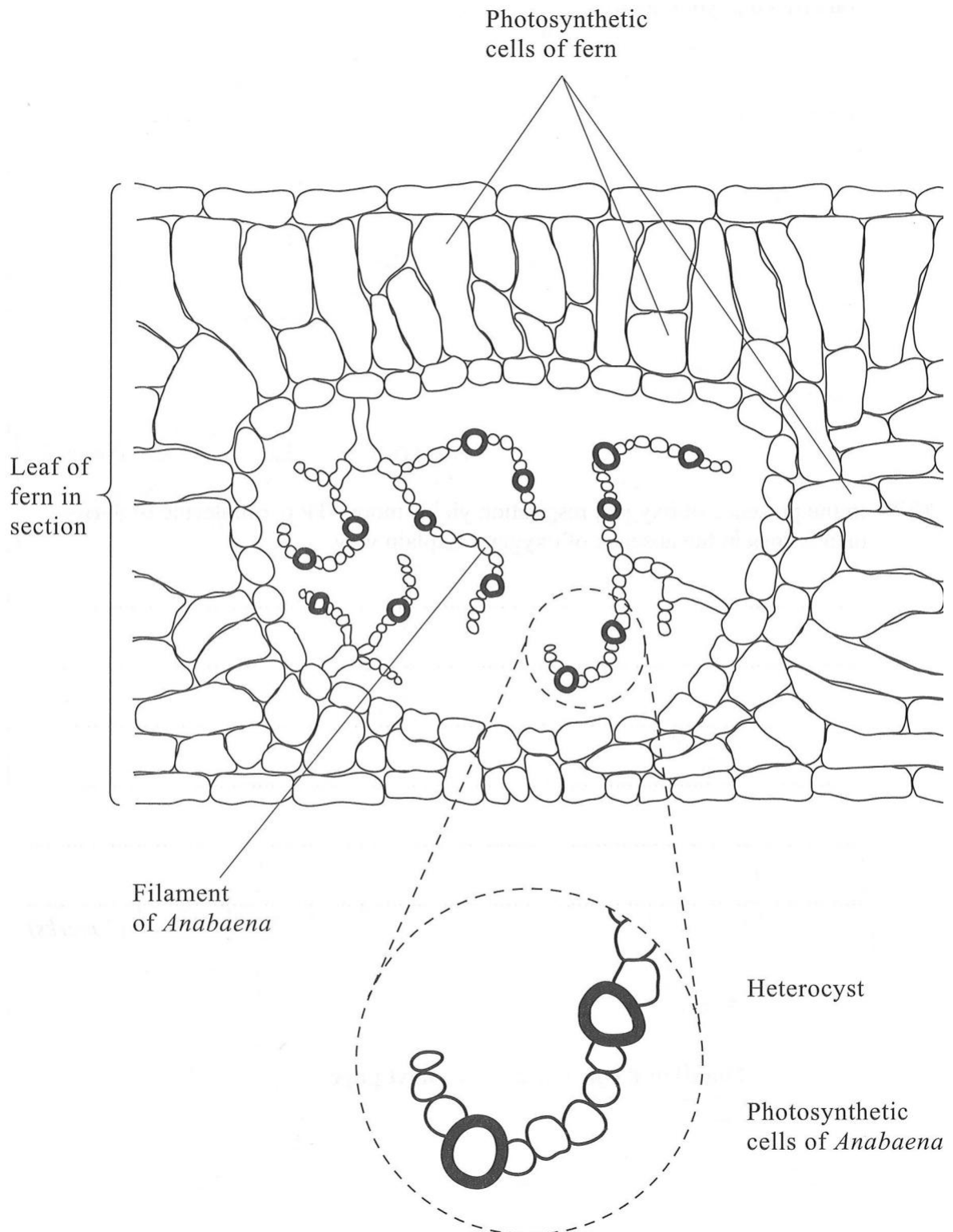

- (i) Suggest how the features of the heterocysts improve the efficiency of the process of nitrogen fixation.

.....

.....

.....

.....

.....

.....

(3)

- (ii) In China, the fern is cultivated and ploughed into fields to act as an organic fertiliser. Explain how ploughing the fern plants into the soil results in an improvement in the growth of the rice crop grown in these fields.

.....

.....

.....

.....

.....

.....

.....

.....

.....

.....

.....

(5)
(Total 15 marks)

21. The diagram represents two of the stages of aerobic respiration that take place in a mitochondrion.

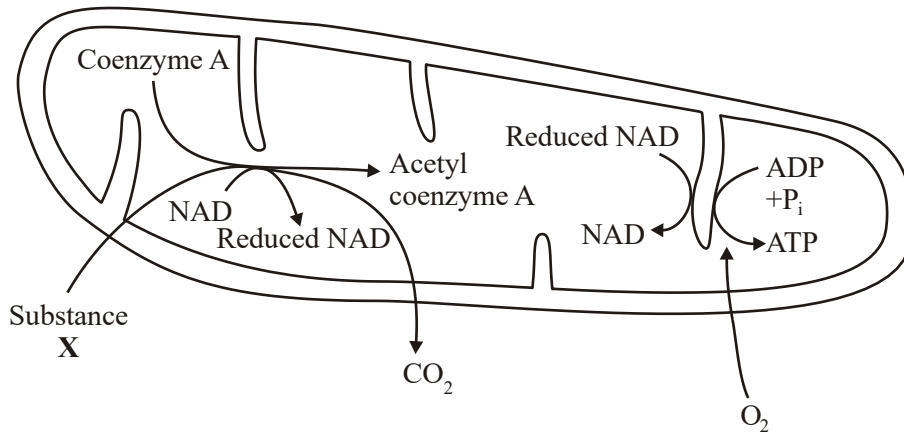

- (a) Name substance X.

.....

(1)

- (b) Which stage of aerobic respiration takes place inside a mitochondrion and is **not** represented on the diagram?

.....

(1)

- (c) Explain why oxygen is needed for the production of ATP on the cristae of the mitochondrion.

.....

.....

.....

.....

.....

.....

(3)

(Total 5 marks)

22. The diagram shows the biochemical pathway involved when one molecule of glucose is respired aerobically.

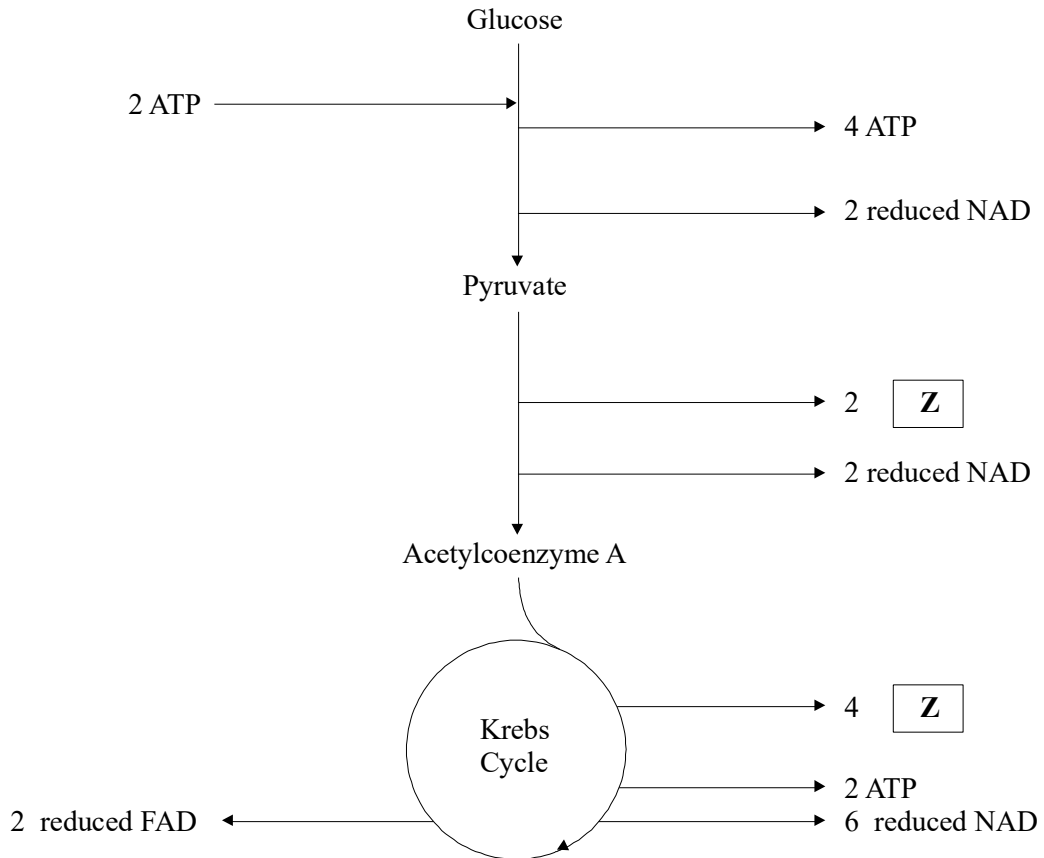

Each reduced NAD molecule leads to the production of 3 ATP molecules.
Each reduced FAD molecule leads to the production of 2 ATP molecules.

- (a) Identify the compound represented by the letter **Z**.

.....

(1)

- (b) Using the information in the diagram, calculate the net number of ATP molecules produced from one molecule of glucose during aerobic respiration.

Net number of ATP molecules.....

(1)

- (c) (i) Describe the part played by oxygen in the process of aerobic respiration.

.....
.....
.....

(2)

- (ii) In the absence of oxygen, anaerobic respiration occurs. In animals, this involves the conversion of pyruvate into lactate without the production of any more ATP molecules. How many molecules of ATP are produced from each glucose molecule in anaerobic respiration ?

.....
.....

(1)

(Total 5 marks)

23. The number of earthworms in a field may be estimated by using frame quadrats. The quadrats are placed at random on the surface of the area being sampled. The ground is then watered with a very dilute solution of formalin. The earthworms which come to the surface are collected and washed.

- (a) (i) Explain why the quadrats should be placed at random.

.....
.....

(1)

- (ii) Throwing a quadrat does not ensure a random distribution. Describe a method by which you could ensure that the quadrats would be placed at random.

.....

.....

.....

.....

(2)

- (b) Give **one** advantage of describing the size of the population in terms of biomass rather than as the number of earthworms collected.

.....

.....

(1)

- (c) Similar sized populations of earthworms were kept in soils at different temperatures. The earthworms were fed on discs cut from leaves. The table shows the number of leaf discs eaten at each temperature.

Temperature/ $^{\circ}\text{C}$	Number of leaf discs eaten
0	0
5	178
10	204
15	174
20	124

Using information in the table, explain how mean soil temperature and feeding activity might affect the size of the earthworm population.

.....

.....

.....

.....

.....

.....

(3)
(Total 7 marks)

24. (a) The diagram shows part of a cell.

Use a label line and the letter 'K' to indicate where Krebs cycle occurs, and another line with the letter 'G' to indicate the site of glycolysis.

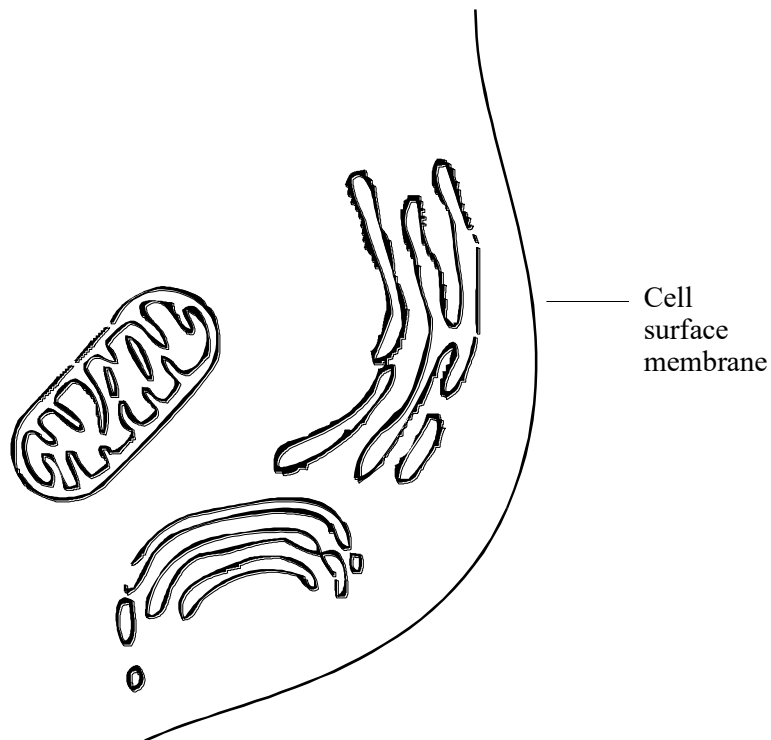

(2)

- (b) (i) Name **two** substances for which there would be net movement into the mitochondria.

1.....

2.....

(2)

- (ii) Name **one** substance for which there would be net movement out of the mitochondria.

.....

(1)

- (c) (i) Glucose is oxidised to pyruvate during the process of glycolysis. Explain why glycolysis is said to involve oxidation.

.....

(1)

- (ii) Explain why ATP is necessary for glycolysis.

.....

(1)

(Total 7 marks)

25. The diagram shows chemical pathways involved in respiration and photosynthesis.

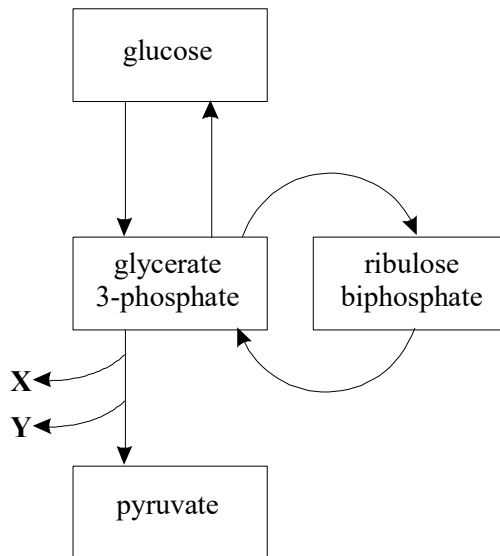

- (a) Name the process that produces pyruvate from glucose.

.....

(1)

(b) Name the compounds labelled X and Y.

X

Y

(2)

(c) (i) In which part of a chloroplast is glycerate 3-phosphate converted into ribulose biphosphate?

.....

(1)

(ii) Describe the role of ribulose biphosphate in photosynthesis.

.....

.....

(1)

(Total 5 marks)

26. (a) Complete the table with a tick if the statement is true or a cross if it is not true.

Statement	Glycolysis	Light-dependent reaction of photosynthesis	Light-independent reaction of photosynthesis
ATP is produced			
ATP is required			
Process takes place in a mesophyll cell from a leaf which has been in the dark for 12 hours			

(3)

- (b) Green bacteria are prokaryotes which are able to photosynthesise. One group of green bacteria requires light and carbon dioxide and uses hydrogen sulphide as a source of hydrogen.

Use this information to describe **two** differences between photosynthesis in these bacteria and photosynthesis in a mesophyll cell from a leaf

- 1
-
- 2
-

(2)
(Total 5 marks)

27. Some liver was ground with a pestle and mortar and the mitochondria separated by centrifugation.

The preparation of mitochondria was used to investigate some aspects of respiration. Various substances were added to the mitochondria and an oxygen electrode was used to monitor the amount of oxygen in the preparation. The diagram shows the trace that was obtained.

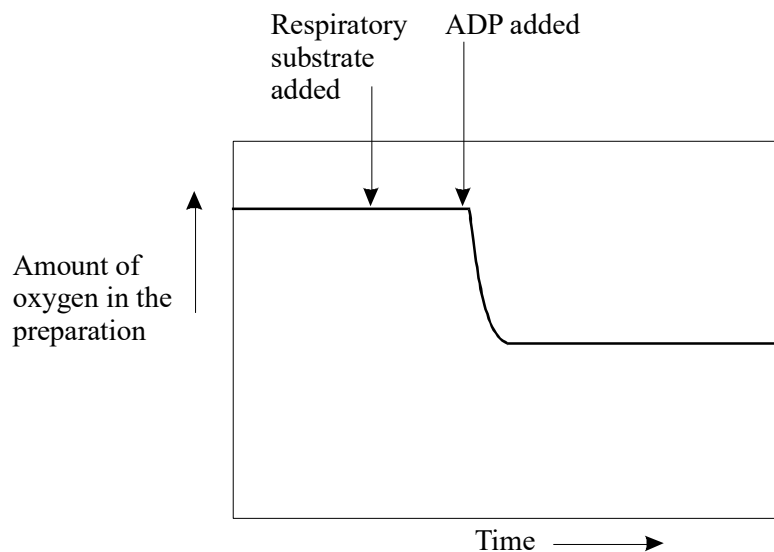

- (i) Explain why acetylcoenzyme A, rather than glucose, was used as a respiratory substrate in this investigation.

.....
.....
.....
.....

(2)

- (ii) Explain the change in the amount of oxygen present in the preparation when the ADP was added.

.....
.....
.....
.....

(2)

(Total 4 marks)

28. The diagram shows two stages occurring in aerobic respiration.

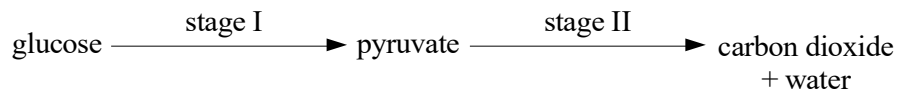

Each of the events or descriptions in the table applies to one or both of the stages. Tick the appropriate boxes to show the stage or stages in which each is involved.

Event or description	Stage I	Stage II
Glycolysis		
Takes place inside the mitochondrion		
Acetylcoenzyme A is involved		
ATP is synthesised from ADP		
Reduced NAD is re-oxidised		

(Total 5 marks)

29. Each of the following statements refers to a process that occurs during photosynthesis or respiration. A 6-C compound refers to a compound with molecules that contain six carbon atoms, 5-C refers to a compound with five carbon atoms, and so on. For each statement give as precisely as possible the stage of photosynthesis or respiration, and the names of the compounds.

- (a) A 6-C compound is broken down into 3-C compounds.

Stage

6-C compound

3-C compound

(2)

- (b) A 5-C compound is combined with a 1-C compound.

Stage

5-C compound

1-C compound

(2)

- (c) 3-C compounds are combined to form a 6-C compound.

Stage

3-C compound

6-C compound

(2)

(Total 6 marks)

30. In an investigation of aerobic respiration, isolated mitochondria were added to a prepared medium containing succinate and inorganic phosphate. Succinate is a 4-carbon compound, which occurs in the Krebs cycle, and can be used as a respiratory substrate. The medium was saturated with oxygen. Equal amounts of ADP were added at one-minute intervals, and measurements were taken of the oxygen concentration in the medium. The graph shows the results.

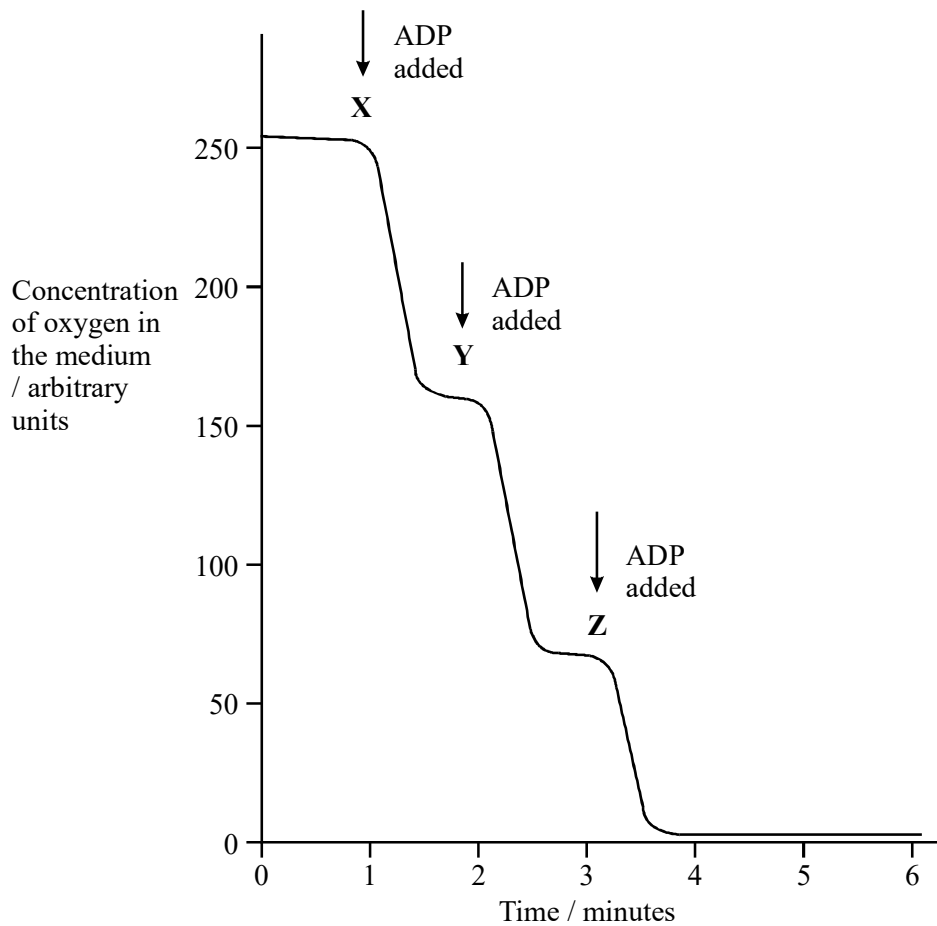

- (a) Why was inorganic phosphate added to the medium?

.....

.....

(1)

(b) Explain why the oxygen concentration in the medium decreased after adding ADP at **X**.

.....
.....
.....
.....
.....
.....

(3)

(c) Explain why the fall in oxygen concentration was the same following the addition of ADP at **X** and at **Y**.

.....
.....

(1)

(d) Explain why the fall in oxygen concentration, following the addition of ADP, was less at **Z** than at **Y**.

.....
.....

(1)

(e) Fresh mitochondria were isolated from cells and a similar experiment was carried out. This time the medium contained glucose instead of succinate. Again, the medium was saturated with oxygen, and excess ADP was added. However, there was almost no fall in oxygen concentration, even after 10 minutes.

(i) Suggest and explain a reason for this observation.

.....
.....
.....
.....

(2)

(ii) Explain, in outline only, how you could test your suggestion.

.....

.....

.....

.....

(1)
(Total 9 marks)

31. In an experiment, lactate containing radioactive carbon was added to a preparation of muscle tissue in the presence of oxygen. The muscle preparation was able to respire some of the lactate and this provided the energy needed to convert the remaining lactate into glycogen. The diagram summarises the biochemical steps involved.

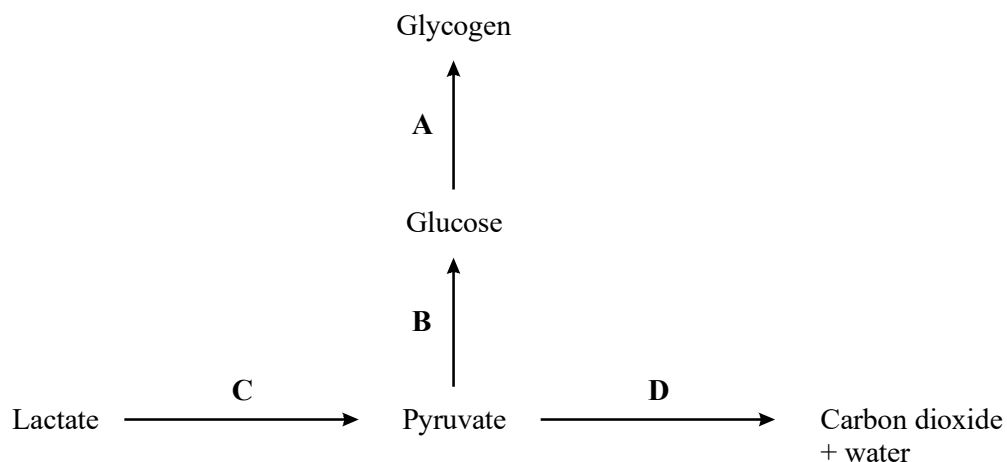

(a) Which **one** of the labelled arrows shows a biochemical conversion in muscle that can proceed only in the direction shown?

.....

(1)

(b) Give the names of the stages in aerobic respiration in which energy is made available from the respiration of lactate.

.....

.....

(2)

The results from the experiment are shown in the table. The values have been rounded to the nearest 100 counts per minute (cpm).

Substance	Total amount of radioactivity found in each substance / cpm	
	at the start of the experiment	at the end of the experiment
Glycogen	0	6200
Lactate	8000	0
Carbon dioxide	0	1200

- (c) Suggest a reason for the lower total amount of radioactivity found at the end of the experiment.

.....

.....

.....

.....

(1)

- (d) Use values from the table to calculate the percentage of lactate that was respired to provide the energy for glycogen synthesis. Show your working.

(2)
(Total 6 marks)

32. S Write an essay on the topic below.

The different ways in which organisms use ATP.

In the answer to this question you should bring together relevant principles and concepts from as many different modules as possible.

Your essay will be marked not only for its scientific accuracy, but also for the selection of relevant material.

The essay should be written in continuous prose.

The maximum number of marks that can be awarded is:

<i>Scientific content</i>	<i>16</i>
<i>Breadth of knowledge</i>	<i>3</i>
<i>Relevance</i>	<i>3</i>
<i>Quality of Written Communication</i>	<i>3</i>

(Total 25 marks)

33. (a) Describe how oxidation takes place in glycolysis and in the Krebs cycle.

.....

.....

.....

.....

.....

.....

(3)

- (b) Water is a waste product of aerobic respiration. Describe how water is formed at the end of aerobic respiration.

.....

.....

.....

.....

(2)

(Total 5 marks)

34. (a) NAD and NADP are coenzymes used in either aerobic respiration or photosynthesis. Complete the table.

	Process	
	Respiration	Photosynthesis
Name of coenzyme	NAD	NADP
Stage(s) in the process where coenzyme is reduced		
Stage in the process where coenzyme is oxidised		

(3)

- (b) Explain how the reduced coenzyme produced in photosynthesis is used.

.....

.....

.....

.....

.....

(2)
(Total 5 marks)

35. (a) (i) Name the three-carbon end product of glycolysis.

.....

(1)

- (ii) Describe how this product is converted into a substance that enters the Krebs cycle.

.....

.....

.....

.....

(2)

- (b) In an investigation, a culture medium containing glucose labelled with radioactive carbon atoms was placed in a flask. A sample of animal cells was added to this medium. The conditions in the flask at the start were anaerobic. Later, oxygen was bubbled through the medium. Samples of gas produced by the cells were tested for radioactivity at regular intervals. The graph shows the results.

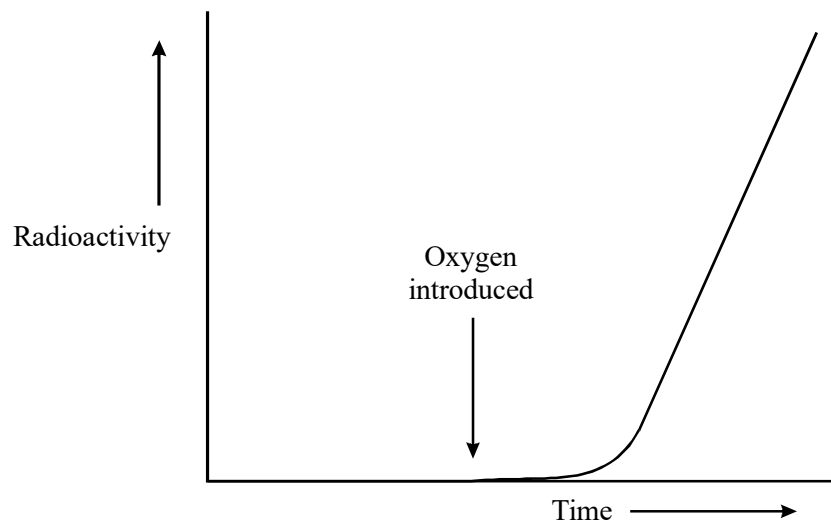

Explain why radioactivity only began to appear in the gas produced by the cells after oxygen was introduced.

.....

.....

.....

.....

.....

(3)
(Total 6 marks)

36. This question should be written in continuous prose, where appropriate. Quality of Written Communication will be assessed in these answers.

- (a) Use your knowledge of classification to arrange *class*, *phylum*, *genus* and *family* in order of decreasing number of species.

largest number of
species

smallest number of
species

.....

(1)

- (b) The diagram shows an amoeba. This is a single-celled organism.

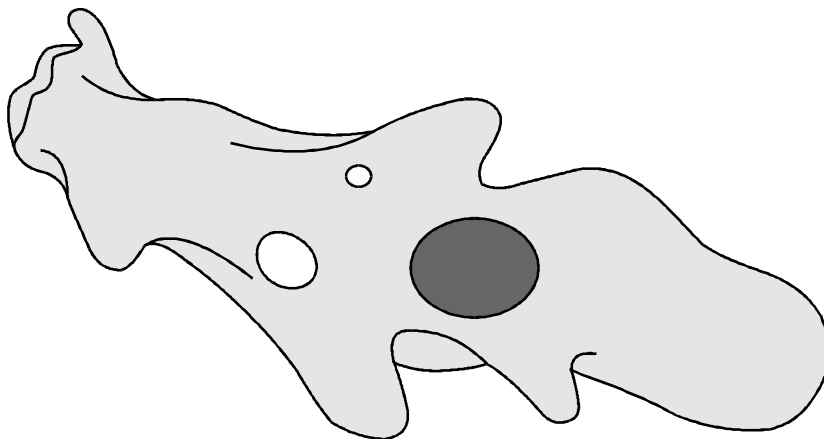

Amoeba is classified as a protist. Giving a different answer in each case, explain why it is **not**

- (i) a prokaryote;

.....
.....

- (ii) a fungus.

.....
.....

(2)

- (c) Cytochrome c is a protein involved in one of the reactions of aerobic respiration in a mitochondrion. The molecular structure of cytochrome c from different species has been analysed. More similarities are present in the structure of cytochrome c in closely related species than in distantly related species.

- (i) Explain what is meant when two species are described as being *closely related*.

.....
.....

(1)

- (ii) A difference in the molecular structure of cytochrome c may arise in a small population that becomes geographically isolated. Explain how the difference may arise and how it may spread in the population.

.....

.....

.....

.....

.....

.....

.....

.....

.....

(4)
(Total 8 marks)

- 37.S The diagram shows apparatus used to measure the oxygen uptake of snails that live on the seashore. The apparatus was kept at a constant temperature.

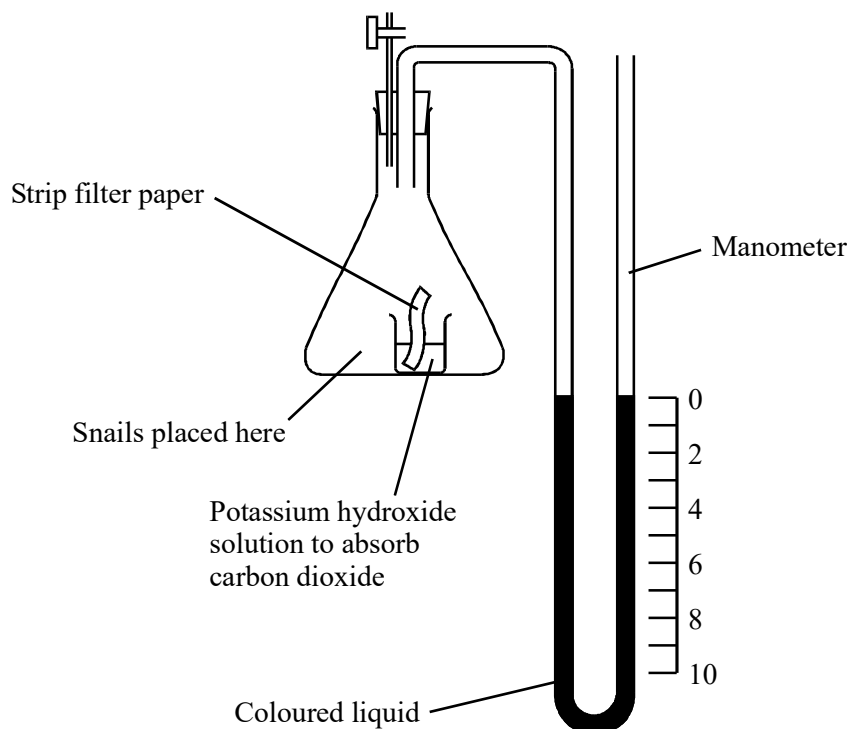

- (a) (i) Explain the purpose of the strip of filter paper in the potassium hydroxide solution.

.....
.....

(1)

- (ii) The level of liquid in the right-hand side of the manometer went down during the experiment. Explain why.

.....
.....
.....
.....

(2)

- (iii) What measurements are needed to calculate the rate of oxygen uptake by the snails in $\text{mm}^3 \text{g}^{-1} \text{h}^{-1}$?

.....
.....
.....

(3)

- (b) Two experiments were carried out using the apparatus shown in the diagram.
- 1 The oxygen uptake of batches of 10 seashore snails kept in moist air was measured at temperatures between 5 °C and 35 °C.
 - 2 Experiment 1 was repeated but with batches of 10 seashore snails covered by aerated seawater.

The experiments were repeated several times and means and standard deviations calculated. The results are shown in the table. The values given are means plus or minus one standard deviation.

Temperature / °C	Oxygen uptake of snails kept in moist air / $\text{mm}^3 \text{g}^{-1} \text{h}^{-1}$	Oxygen uptake of snails kept in seawater / $\text{mm}^3 \text{g}^{-1} \text{h}^{-1}$
5	35 ± 2	28 ± 8
10	34 ± 6	32 ± 3
15	36 ± 3	35 ± 3
20	86 ± 8	52 ± 10
25	141 ± 13	96 ± 15
30	132 ± 14	108 ± 9
35	120 ± 16	79 ± 21

- (i) Describe **one** similarity and **one** difference between the pattern of mean oxygen uptake of the snails kept in moist air and those covered by seawater.

.....

.....

.....

.....

(2)

- (ii) Explain why valid conclusions cannot be drawn about the trends in oxygen uptake at temperatures of 25 °C and above.

.....
.....
.....
.....

(2)
(Total 10 marks)

38. (a) Mitochondria in muscle cells have more cristae than mitochondria in skin cells. Explain the advantage of mitochondria in muscle cells having more cristae.

.....
.....
.....
.....

(2)

- (b) Substance X enters the mitochondrion from the cytoplasm. Each molecule of substance X has three carbon atoms.

- (i) Name substance X.

.....

(1)

- (ii) In the link reaction substance X is converted to a substance with molecules effectively containing only two carbon atoms. Describe what happens in this process.

.....
.....
.....
.....

(2)

- (c) The Krebs cycle, which takes place in the matrix, releases hydrogen ions. These hydrogen ions provide a source of energy for the synthesis of ATP, using coenzymes and carrier proteins in the inner membrane of the mitochondrion.

Describe the roles of the coenzymes and carrier proteins in the synthesis of ATP.

.....

.....

.....

.....

.....

.....

(3)
(Total 8 marks)

39. Write an essay on the topic below.

Energy transfers which take place inside living organisms.

In the answer to this question you should bring together relevant principles and concepts from different parts of the specification.

Your essay will be marked not only for its scientific accuracy, but also for the selection of relevant material.

The essay should be written in continuous prose.

The maximum number of marks that can be awarded is:

<i>Scientific content</i>	<i>16</i>
<i>Breadth of knowledge</i>	<i>3</i>
<i>Relevance</i>	<i>3</i>
<i>Quality of Written Communication</i>	<i>3</i>

(Total 25 marks)

40. The boxes in the diagram represent substances in glycolysis, the link reaction and the Krebs cycle.

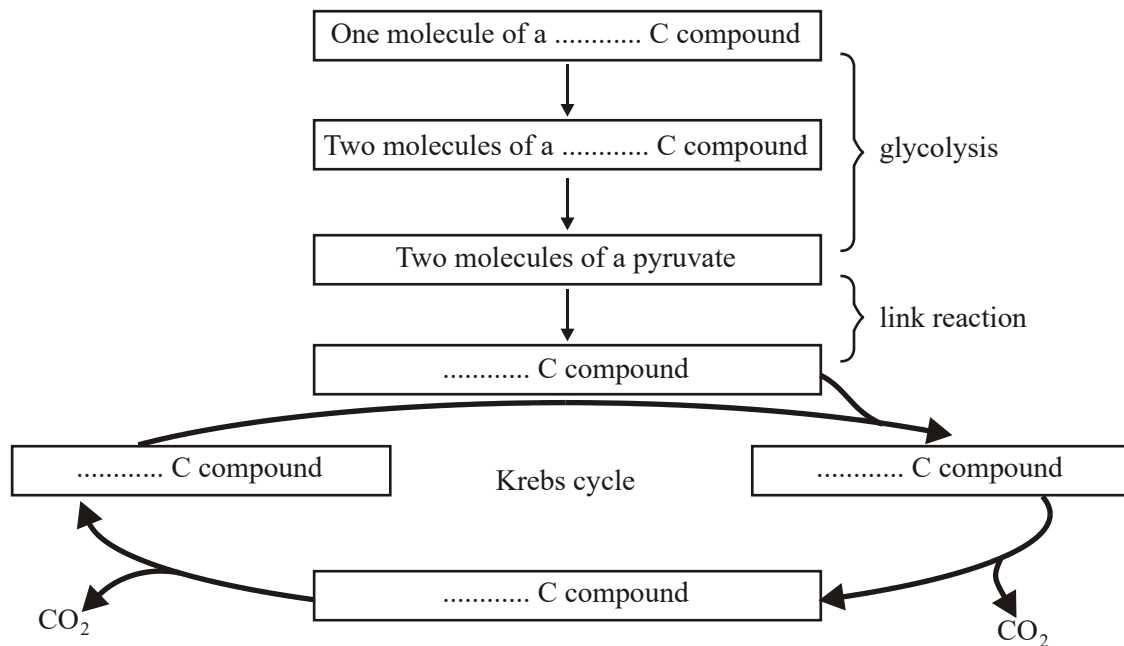

(a) Complete the diagram to show the number of carbon atoms present in **one** molecule of each compound.

(2)

(b) Other substances are produced in the Krebs cycle in addition to the carbon compounds shown in the diagram. Name **three** of these other products.

1

2

3

(3)

(Total 5 marks)

41. S In an investigation, the effects of caffeine on performance during exercise were measured.

One group of athletes (**A**) was given a drink of decaffeinated coffee. Another group (**B**) was given a drink of decaffeinated coffee with caffeine added. One hour later the athletes started riding an exercise bike and continued until too exhausted to carry on.

Three days later the same athletes repeated the experiment, with the drinks exchanged.

- (a) (i) The researchers added caffeine to decaffeinated coffee. Explain why they did not just use normal coffee.

.....

(1)

- (ii) The performance of the athletes might have been influenced by how they expected the caffeine to affect them. How could the researchers avoid this possibility?

.....

(1)

During the exercise the concentrations of glycerol and fatty acids in the blood plasma were measured. The results are shown in the table.

Drink	Mean time to exhaustion /minutes	Mean concentration of blood glycerol/ mmol dm^{-3}	Mean concentration of blood fatty acids/ mmol dm^{-3}
With caffeine	90.2	0.20	0.53
Without caffeine	75.5	0.09	0.31

- (b) (i) Describe the effect of caffeine on exercise performance.

.....

(1)

- (ii) Suggest **one** explanation for the higher glycerol and fatty acid concentrations in the blood plasma of the athletes after they were given caffeine.

.....

(2)

- (c) The researchers measured the volumes of carbon dioxide exhaled and oxygen inhaled during the exercise. From the results they calculated the respiratory quotient (RQ), using the formula

$$\text{RQ} = \frac{\text{volume of carbon dioxide exhaled per minute}}{\text{volume of oxygen inhaled per minute}}$$

When a person is respiring carbohydrate only, RQ = 1.0

When a person is respiring fatty acids only, RQ = 0.7

- (i) The basic equation for the respiration of glucose is

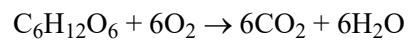

Explain why the RQ for glucose is 1.0.

.....

.....

.....

.....

(2)

- (ii) The researchers found that, when the athletes were given the drink containing caffeine, their mean RQ was 0.85. When given the drink without caffeine their mean RQ was 0.92.

The researchers concluded that when the athletes had caffeine they used glycogen more slowly than when they did not have caffeine, and that the store of glycogen in their muscles was used up less quickly during the exercise.

Explain the evidence from the information above and from the table which supports these conclusions.

.....

.....

.....

.....

.....

.....

.....

(3)
(Total 10 marks)

42. The diagram shows the structure of a mitochondrion.

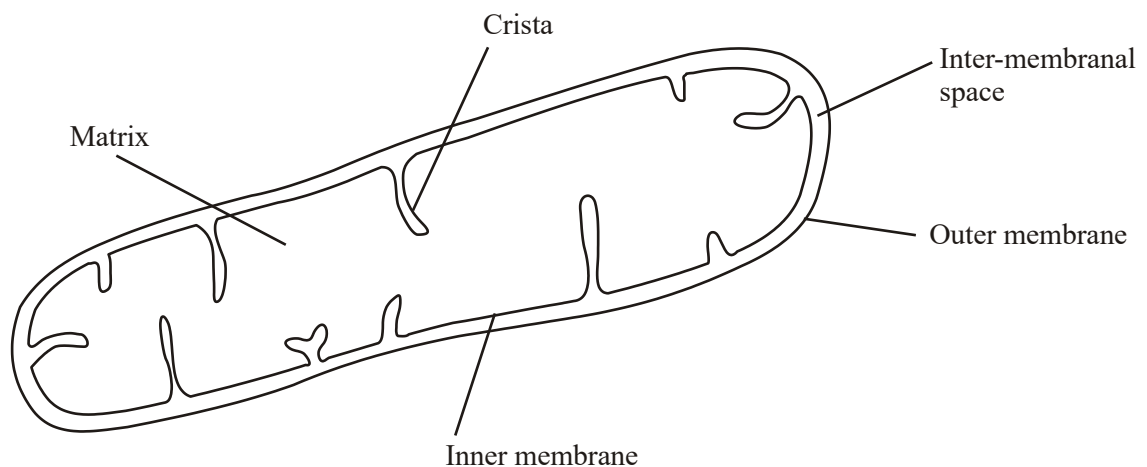

- (a) In which part of the mitochondrion does the Krebs cycle take place?

.....

(1)

(b) Name **two** substances for which there would be net movement into the mitochondrion.

1

2

(2)

(c) The mitochondria in muscles contain many cristae. Explain the advantage of this.

.....

(2)

(Total 5 marks)

43. (a) The table contains some statements relating to biochemical processes in a plant cell. Complete the table with a tick if the statement is true or a cross if it is not true for each biochemical process.

Statement	Glycolysis	Krebs cycle	Light-dependent reaction of photosynthesis
NAD is reduced			
NADP is reduced			
ATP is produced			
ATP is required			

(4)

(b) An investigation was carried out into the production of ATP by mitochondria. ADP, phosphate, excess substrate and oxygen were added to a suspension of isolated mitochondria.

(i) Suggest the substrate used for this investigation.

.....

(1)

(ii) Explain why the concentration of oxygen and amount of ADP fell during the investigation.

.....

.....

.....

.....

(2)

(iii) A further investigation was carried out into the effect of three inhibitors, **A**, **B** and **C**, on the electron transport chain in these mitochondria. In each of three experiments, a different inhibitor was added. The table shows the state of the electron carriers, **W-Z**, after the addition of inhibitor.

Inhibitor added	Electron carrier			
	W	X	Y	Z
A	oxidised	reduced	reduced	oxidised
B	oxidised	oxidised	reduced	oxidised
C	reduced	reduced	reduced	oxidised

Give the order of the electron carriers in this electron transport chain. Explain your answer.

Order

Explanation

.....

.....

(2)
(Total 9 marks)

44. Each of the following statements refers to a process that occurs either during photosynthesis or during respiration. A 6C compound refers to a compound whose molecules contain six carbon atoms, 5C refers to a compound with five carbon atoms, and so on.

For each statement, give as precisely as possible the stage of photosynthesis or respiration and the names of the compounds.

- (a) A 6C compound is broken down into two 3C compounds.

Stage

6C compound

3C compound

(2)

- (b) A 5C compound is combined with a 1C compound.

Stage

5C compound

1C compound

(2)

- (c) 3C compounds are combined to form a 6C compound.

Stage

3C compound

6C compound

(2)

(Total 6 marks)

Mowing was also found to affect the number of insect species found on a roundabout. Use your knowledge of succession to explain how.

.....

.....

.....

.....

.....

.....

.....

.....

.....

.....

.....

.....

.....

.....

(5)

- (c) The carbon dioxide concentration was monitored at ground level in the centre of a small roundabout. The measurements were made on a summer day. Describe and explain how you would expect the concentration of carbon dioxide to fluctuate over the period of 24 hours.

.....

.....

.....

.....

.....

.....

.....

.....

.....

.....

.....

(5)

(Total 15 marks)